

VP - SEVENTEEN



"WHITE LIGHTNING"

HISTORY OF PATROL SQUADRON SEVENTEEN

History of Patrol Squadron SEVENTEEN began on 1 September 1950. Known as VP-722, a "Weekend Warrior" Reserve Squadron, the unit was activated and became the first Reserve Squadron to participate in the Korean conflict. Staging operations from MCAS Iwakuni, Japan, VP-772 flew 425 missions over enemy territory in the four engine heavy patrol bomber, P4Y-2 "Privateer."

At the conclusion of the war, having been newly designated Patrol Squadron SEVENTEEN (VP-17), the unit returned to its new home duty station, NAS Whidbey Island, Washington. After settling down at Whidbey and having received a new aircraft, the Lockheed P2V-6 "Neptune," the squadron began establishing itself as one of the best ASW units in the Pacific.

In July 1956, VP-17 was designated Heavy Attack Mining Squadron TEN (VA (HM) 10), becoming the only heavy attack mining squadron in the Pacific. For the next three years VA (HM) 10 deployed several times to Alaska, establishing an outstanding flying record, which resulted in the squadron being awarded the Chief of Naval Operations Commendation. On 1 July 1959, VA

(HM) 10 was re-designated Patrol Squadron SEVENTEEN and the squadron resumed its antisubmarine warfare operations in the Pacific.

During the next several years, VP-17 continued with normal operations and training missions making deployments to Alaska and the Western Pacific. In 1966, the squadron was the recipient of the coveted "Triple Crown" of the ASW, Chief of Naval Operations Safety Award, the Chief of Naval Operations Maintenance Award, and the Battle Efficiency "E" for Pacific Squadrons. In connection with the Battle Efficiency "E", VP-17 was awarded the Isbell ASW trophy signifying excellence in air anti-submarine warfare maneuvers. Thus, the squadron had established itself as the outstanding ASW unit in the Pacific.

During the years 1966-1972, VP-17, now known as the "White Lightning" squadron, completed deployments to Sangley Point, Philippines, Iwakuni, Japan, and Naga, Okinawa. During this time, they made valuable contributions to the U.S. efforts in Southeast Asia, by participating in operation Market Time. Working out of detachments in UTAPAO. Thailand, Cam Rahn

Bay, South Vietnam, and Cubi Point, Philippines, Vp-17 flew over 1250 combat sorties, accumulating 12,500 accident free flight hours. In the course of these missions, VP-17 was responsible for the detection of several North Vietnamese infiltrator trawlers, and the destruction of four. The outstanding achievements of the "White Lightning" crews received wide recognition through numerous Air Medals and Navy Commendation Medals. The President of the United States also recognized the squadron's superior performance by awarding the Distinguished Flying Cross to a patrol plane pilot for the first time since the Korean War.

The officers and men of PATRON SEVENTEEN have demonstrated outstanding ability flying search and rescue missions. In 1971, a crew was responsible for the ultimate rescue of the lone survivor from a sunken freighter and again, in 1972, VP-17 located and assisted in rescuing 26 survivors of a burning merchant vessel.

Excelling in all areas, VP-17 was awarded a Meritorious Unit Commendation for outstanding performance in the spring and

summer of 1970 and again in the winter of 1970. PATRON SEVENTEEN was also the first Pacific Fleet VP squadron to take part in the joint North-South American training exercises, UNITAS XII. The outstanding success of this detachment reflects the spirit and team effort which has been the key to the squadron's success.

From May to November 1973, we were deployed to NAS CUBI POINT, R.P. As the first VP squadron to complete a full deployment after the cessation of hostilities in Viet-Nam, the "White Lightning" Squadron scored an impressive 5500 accident-free hours in support of Seventh Fleet, while the "ground-pounders" worked 75,000 man-hours to keep us in the air. In the following pages, you will see the people who made the deployment safe and successful.

1
9
5
0



1
9
7
3

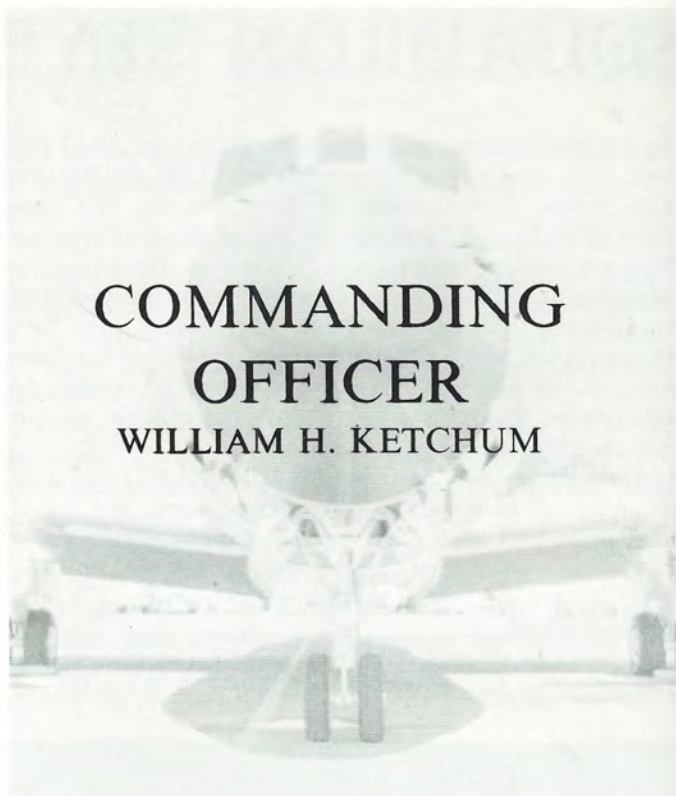

COMMANDING
OFFICER
WILLIAM H. KETCHUM

To the Officers and Men of Patrol Squadron SEVENTEEN

One of the most precious things a person or nation can have is FREEDOM. This commodity is so dear that it is impossible to know just how important it is until one has lost it. The members of this command (dependents included) have directly committed themselves to preserving our continued freedom, as well as that of our allies. While day by day it may have been difficult or impossible to measure your worth to the course of freedom, the total contribution by VP-17 has been noteworthy and predominate.

I fully realize the loneliness and agony of family separation caused from necessary deployments. However, as I look back, I view our service to the United States with pride, knowing it was all worthwhile.

It has been a distinct pleasure to have been a part of this unit. Working together, we were able to function as the need existed. When necessary, we are a family, a friend, a travel agency, a church, and a club; but most importantly, we were and are a highly professional ASW VP squadron.

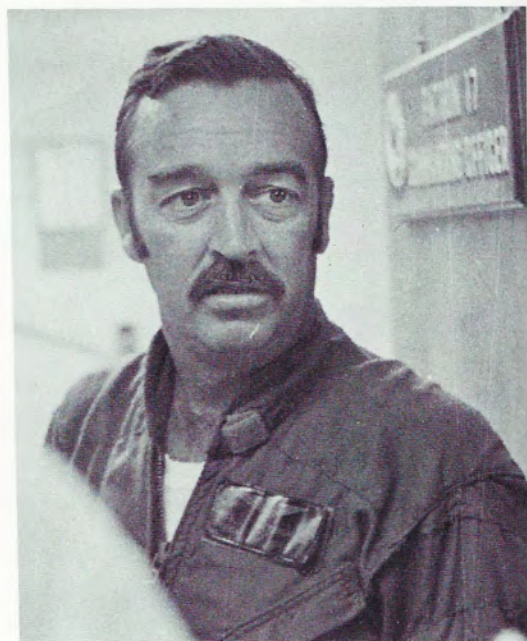

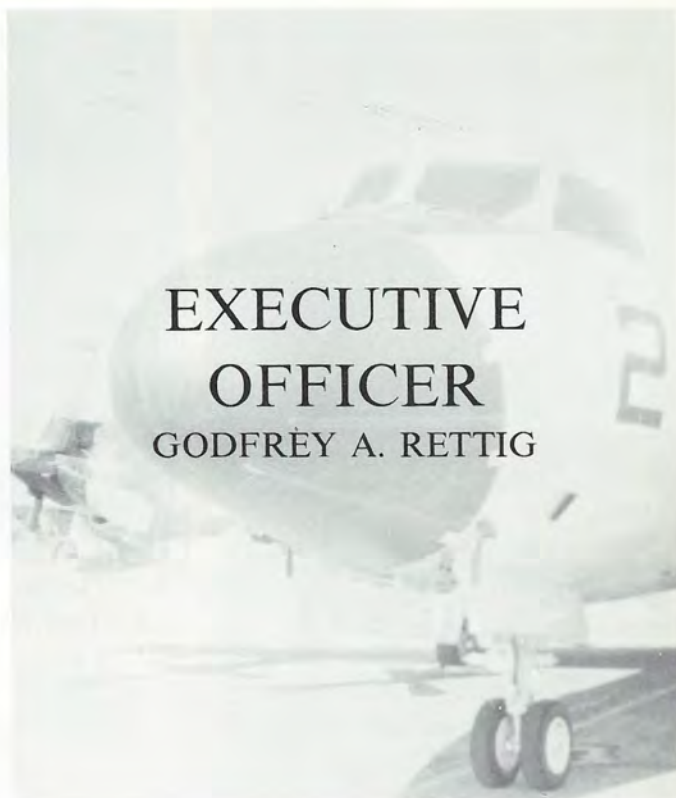

Born in Chicago on 15 September 1934, Commander Godfrey A. RETTIG attended two years of college at the University of Illinois prior to entering the Navy in 1954 under the Naval Aviation Cadet (NAVCAD) Program. He completed flight training, receiving his commission and designation as a Naval Aviator in August 1956.

Commander RETTIG's first operational tour was with Airborne Early Warning Squadron FOURTEEN (WV-14) based at NAS Barbers Point, Hawaii, flying the WV-2 and R7V aircraft. In 1959, he was transferred to the Basic Training Command and reported to Training Squadron TWO (VT-2) at NAS Whiting Field, Florida, as a Flight Instructor in the T-28 aircraft. Following a tour as Flight and NATOPS Officer in Hawaii based Patrol Squadron SIX (VP-6), Commander RETTIG was assigned to the USS BON HOMME RICHARD (CVA-31) as Assistant Combat Information Center and Electronic Warfare Officer. In 1966, he reported to the Naval Postgraduate School at Monterey, California, receiving a BS in Engineering Science. In 1968, Commander RETTIG returned to Patrol Aviation as Operations Officer of Patrol Squadron ONE (VP-1), homeported at Whidbey Island, Washington. During this assignment he deployed to the Philippines and Japan, flying P2V-7 and P3B aircraft. In 1970, he was assigned to the JCS serving as Space Systems Officer in the Joint Continental Defense Systems Integration Planning Staff (JSIPS). He currently serves Patrol Squadron SEVENTEEN (VP-17) as Executive Officer. Commander RETTIG's decorations and awards include the Meritorious Unit Citation, and the Vietnam Campaign Medal.

Commander RETTIG is married to the former Paula Robb Shadrick-Barager of San Diego, California. They reside with their five children, Guy, Christina, Cathleen, James, and Jeffrey in Ewa Beach, Hawaii.



Executive Department



Safety Officer
LCDR Mike McBride
NATOPS Officer
LT. Gerry Spaulding
Asst. NATOPS Officer
LT. Bob Barclay
NATOPS F/E
ADRC Jack Schragger
Medical Officer
LCDR Dave "Doc" Bakken
Asst. Doctor
HM1 Donnan

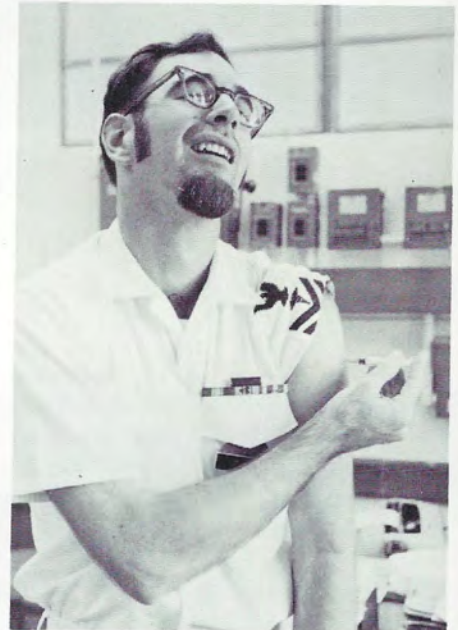



ADMIN Department

Admin Officer
 LCDR Larry Croll
 Asst. Admin Officer
 LTJG Bill Overend
 Legal Officer
 LT John Rowbottom
 CMCO
 LTJG Glenn Knechtel
 CMCO
 SN Brent Oldland
 YNC Jose Leonida
 YN 3 Bob Bailey
 YN 3 John Jackson

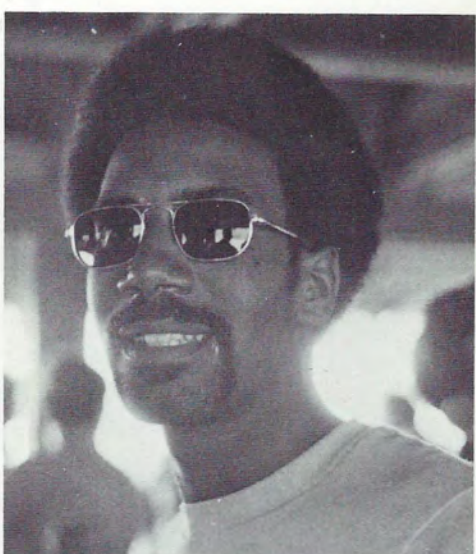
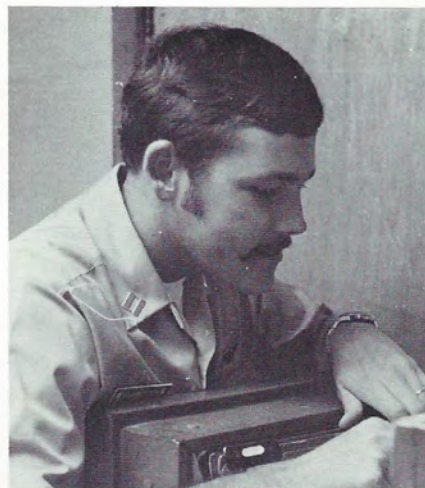
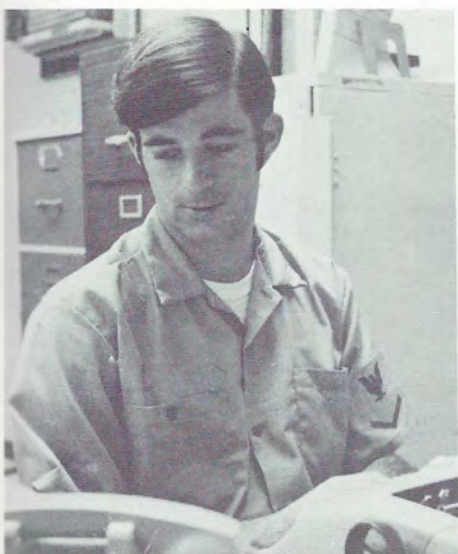

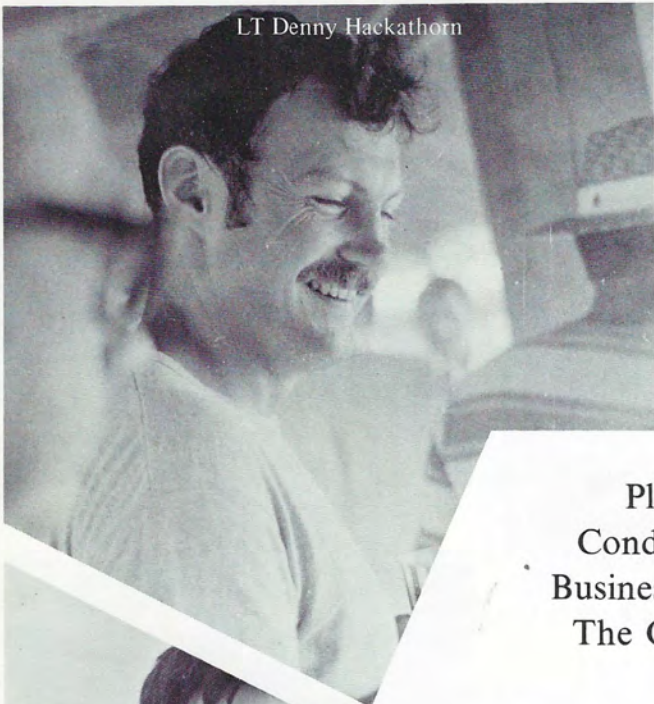

LT Denny Hackathorn

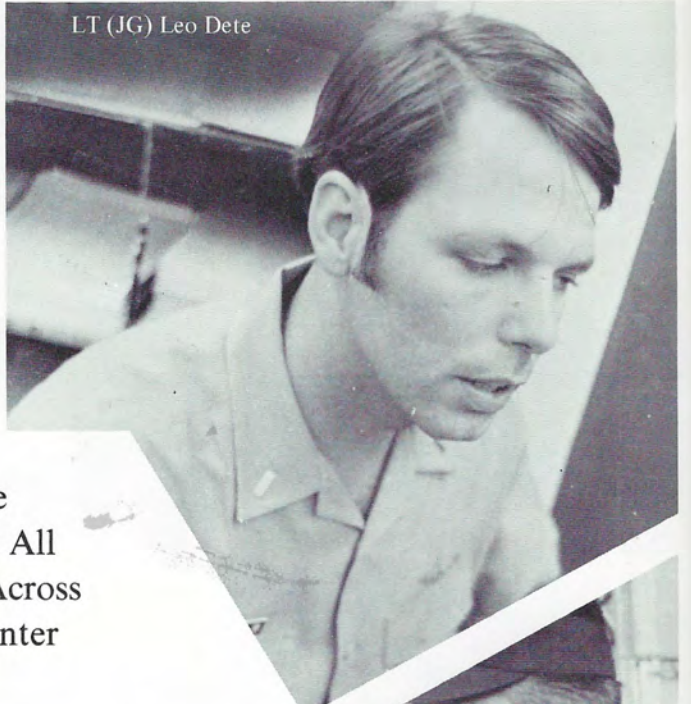

LT (JG) Leo Dete

Please
Conduct All
Business Across
The Counter

PERSONNEL

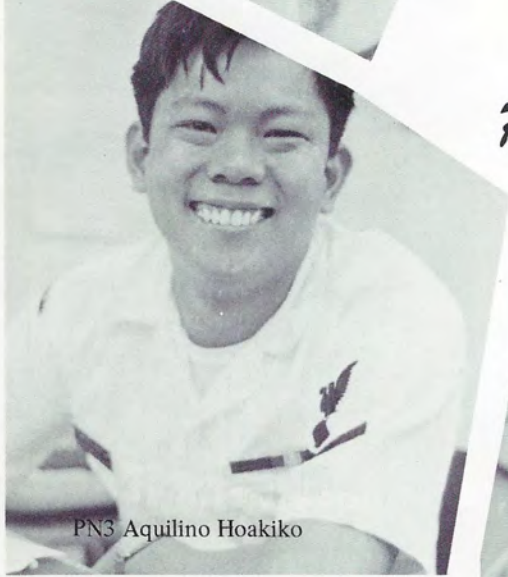

PN3 Aquilino Hoakiko



PNSN Kevin Storman



PN1 Oliver Lee

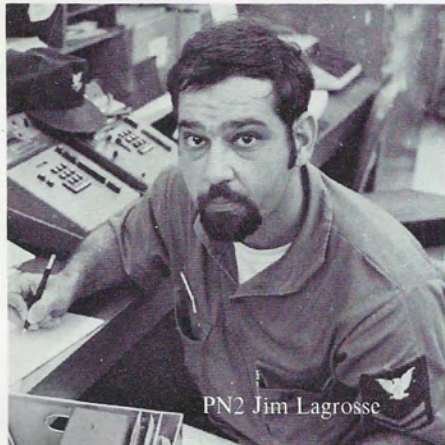

PN2 Jim Lagrosse

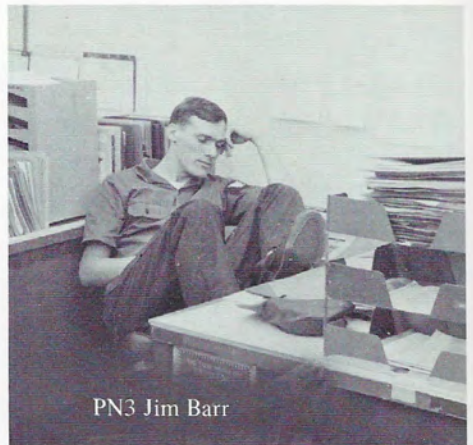

PN3 Jim Barr

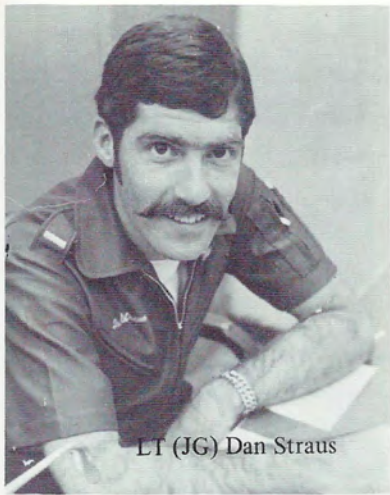

LT (JG) Dan Straus



PN3 Mike Gebhart

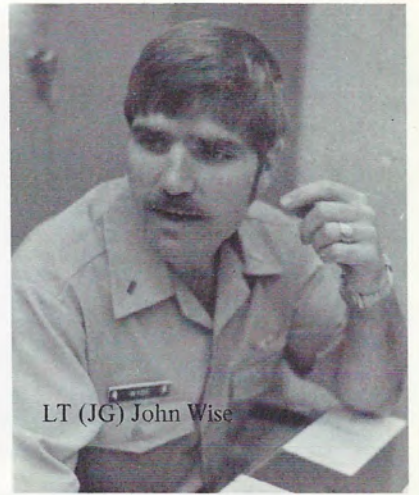

LT (JG) John Wise

Personal



AMSC Tony Lathrop



LCDR Jim Fields



LT (JG) Bill Blase

Services



LT (JG) Steve Root



LT Paul Holder

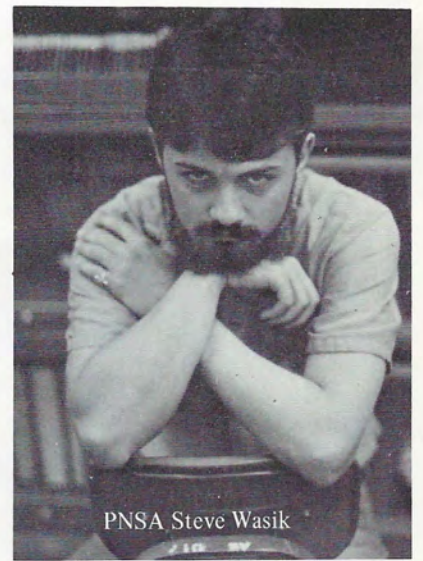

PNSA Steve Wasik

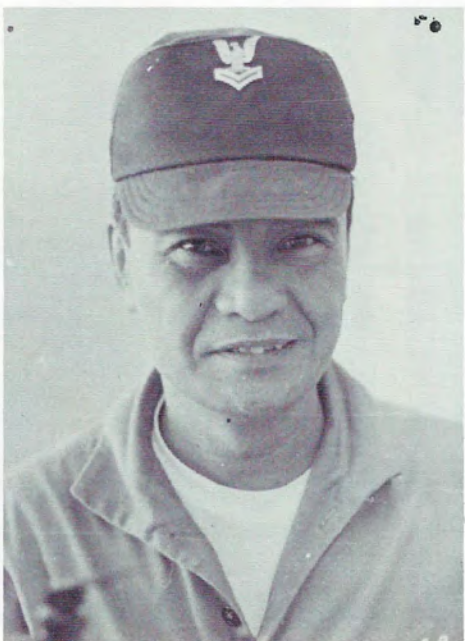
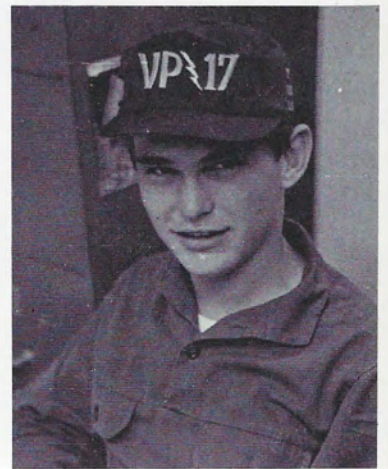
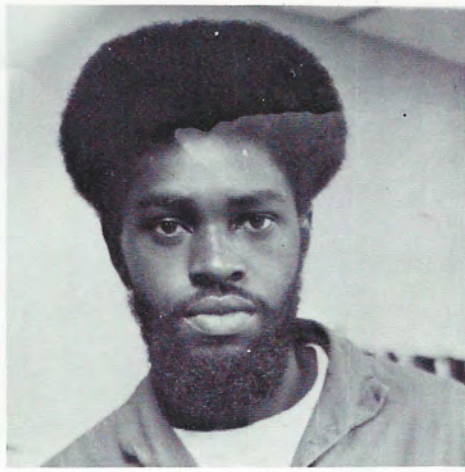

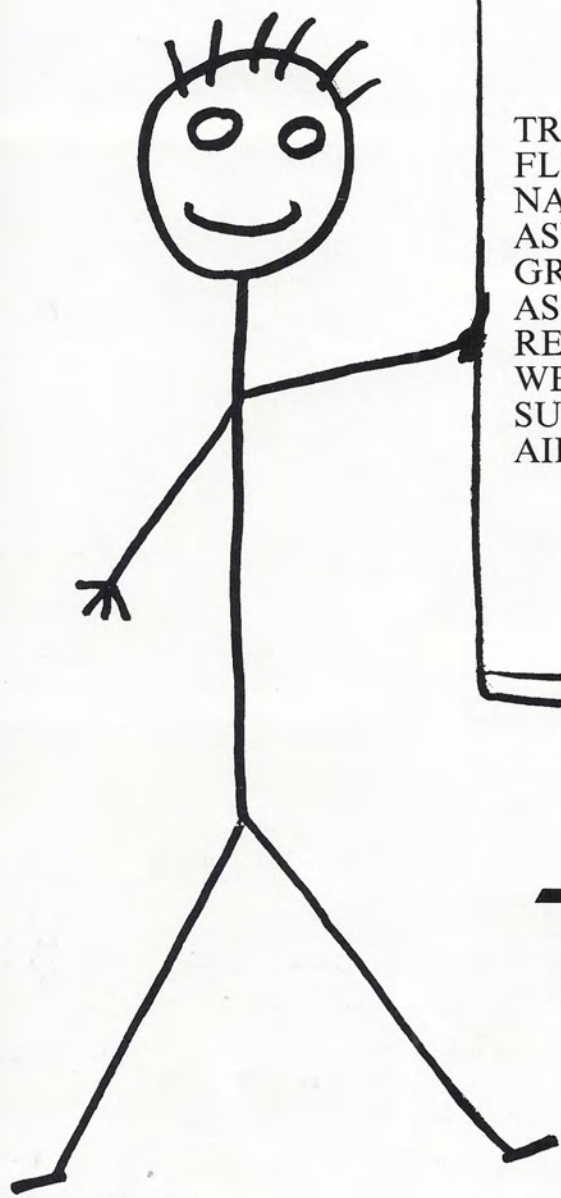

TRAINING
FLIGHT TRNG
NAV TRNG
ASW TACCO
GROUND TRNG
ASST GROUND TRNG
READINESS
WEAPONS TRNG
SURVIVAL TRNG
AIRCREW DIV OFF.

LCDR Jack Williams
Lt. Pat Maley
Lt. Ray Laturno
Lt. Bob Scruggs
Lt. Mark Byars
Ltjg Dave Larson
Ltjg Pete Magoun
Ltjg Jim Carlson
Ltjg Bob Gastall
Lt. Doug McWhorter

ADJC Ron Thaut
2+2=5

TRAINING DEPT.

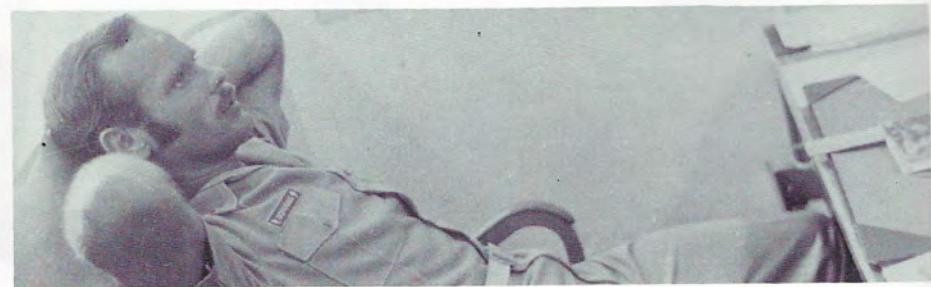

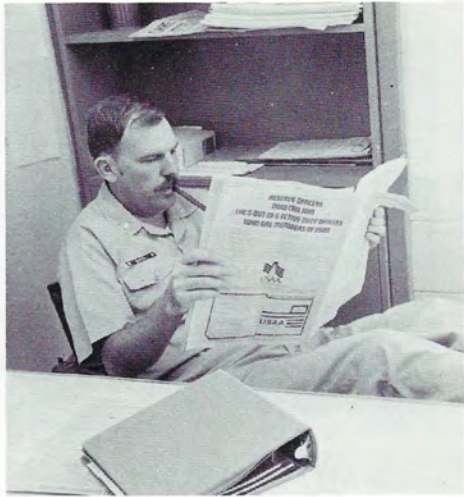

OPS OFFICER – LCDR William Boyd
 ASST OPS OFFICER – LT James Humphrey
 OPS/ADMIN – LTJG George Andersen
 COMM – LT Dudley Chase
 NAVIGATION – LTJG Robert Brooks
 FLIGHT/SKEDS – LT John Carter
 ASST COMM/RPS – ENS George Vogel
 AA Rex Evans
 YNSN John Bryan
 PTAN Tim Bachran





SCHEDULES – LTJG Frank Mikusi
 TACTICS – LT Paul Sanger
 ASW INTELLIGENCE – LTJG Mike Romeo
 ASW SEARCH – LT Jim McGroarty
 ASW LOCAL – LT Steve Peck
 ASW LOCAL – LTJG Jon Dresel

ASW ATTACK – ENS Tom Goen
 PH2 Doug Siefkin
 AA Henry Van Hoose
 YNSN Larry Anderson
 ASST SKEDS – AWC Willis Stagner





*When I Grow Up!!!
I Wanna Be . . .*



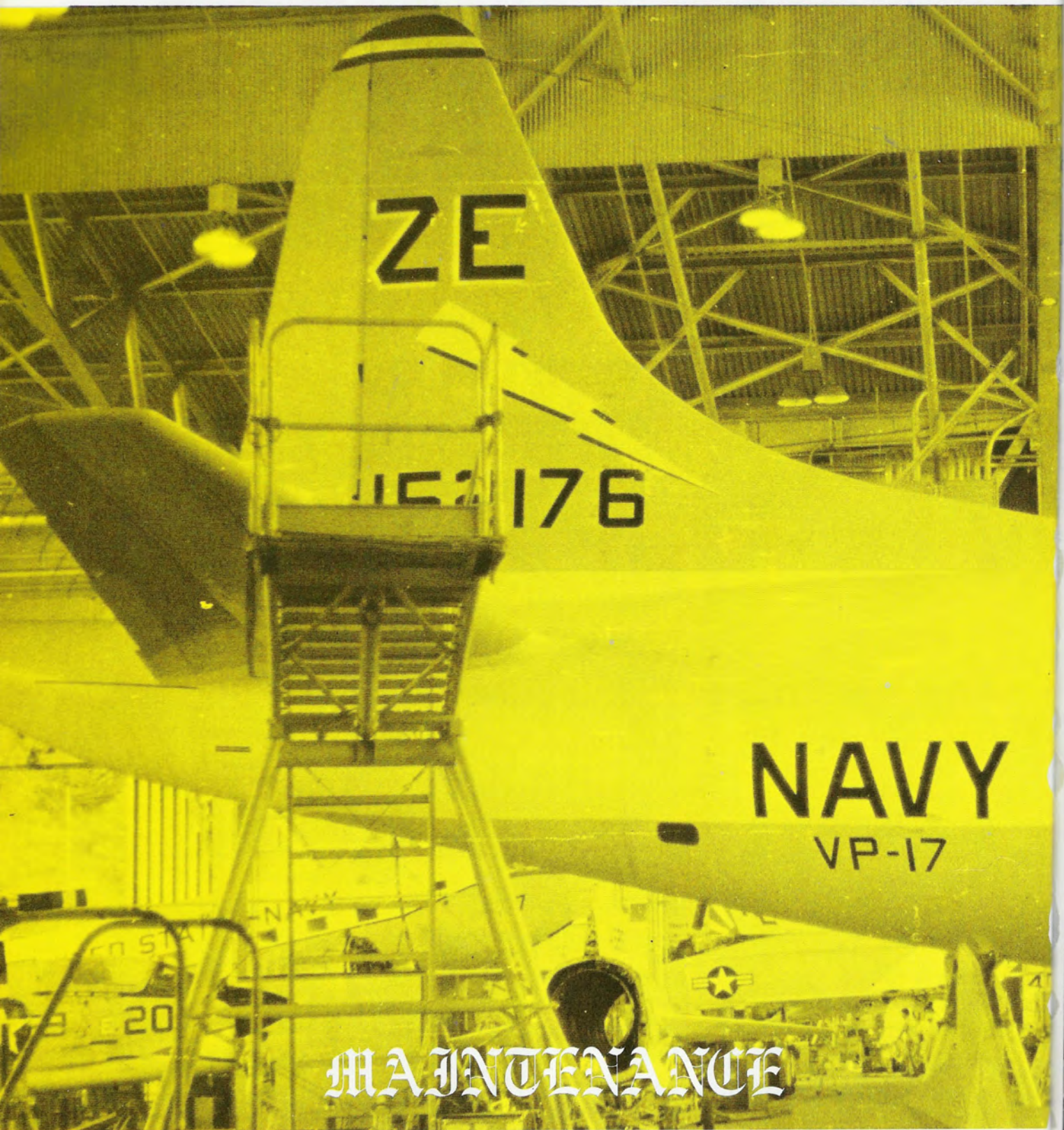

MAINTENANCE

Maintenance Officer Main/Mat Control

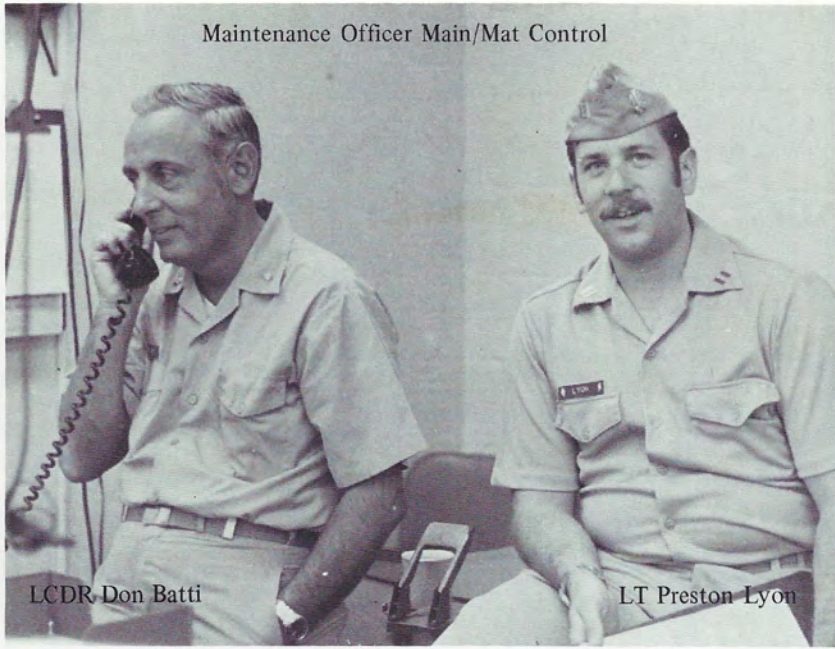

LCDR Don Batti

LT Preston Lyon

Aircraft Div



LT Steve Vaughan

AV/Arm Div

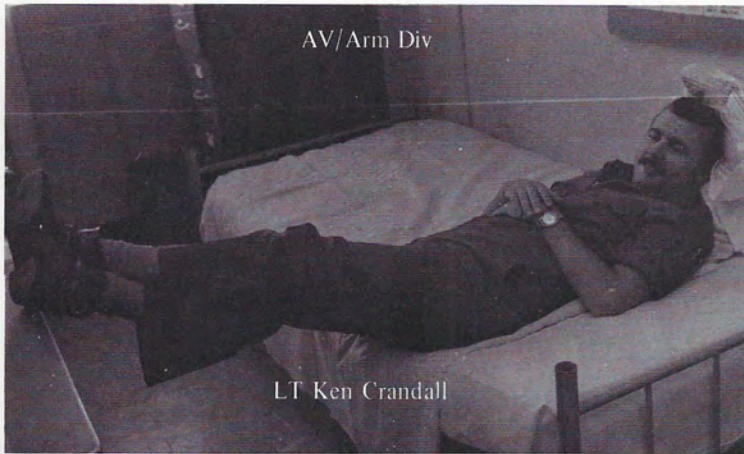

LT Ken Crandall

Asst Maintenance



LCDR Bill Vincent

Maint Admin/Trng/Data Analysis

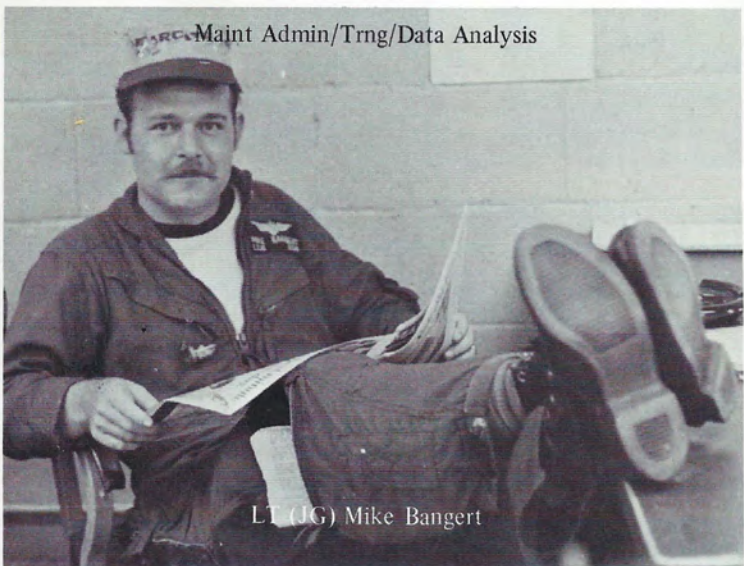

LT (JG) Mike Bangert

WO Gerry Murdoff



MATERIEL CONTROL

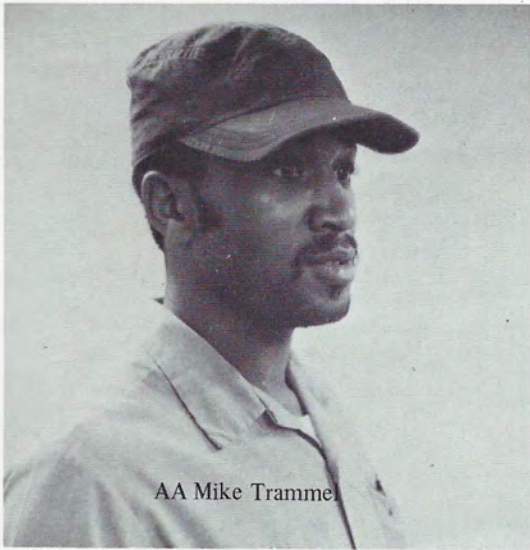

AA Mike Tramme



LT Ted Morrison

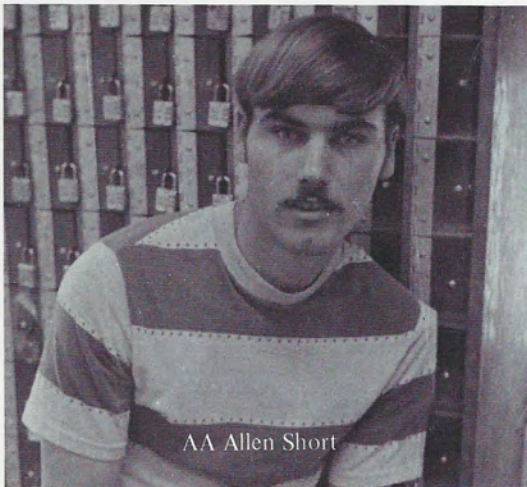

AA Allen Short



AK2 Salvador Biando

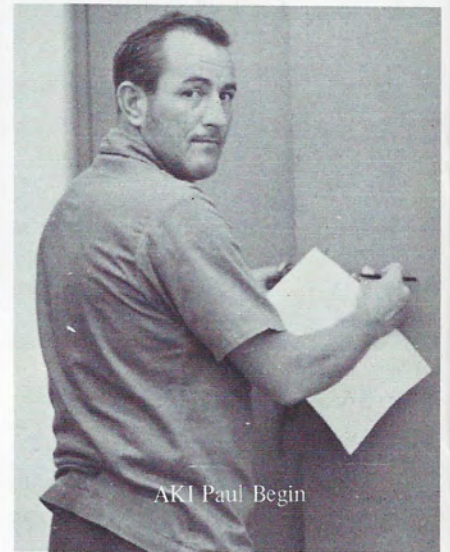

AKI Paul Begin

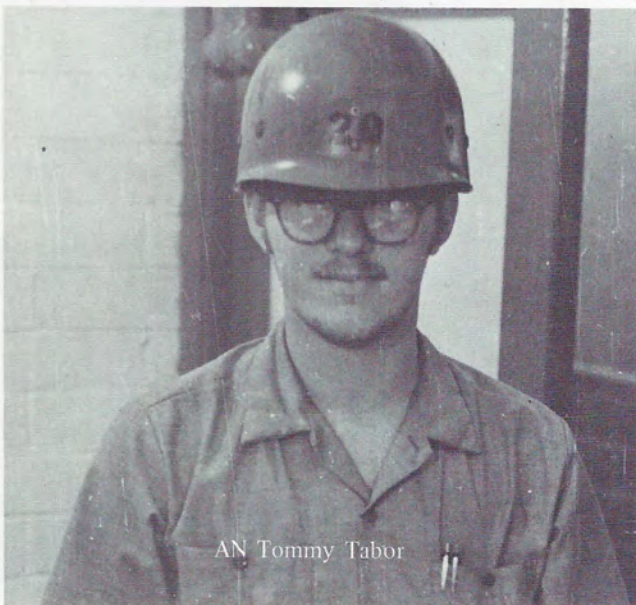

AN Tommy Tabor

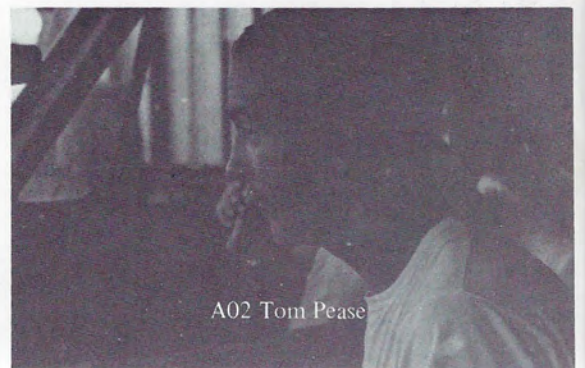

A02 Tom Pease



LTJG Jerry Mooney

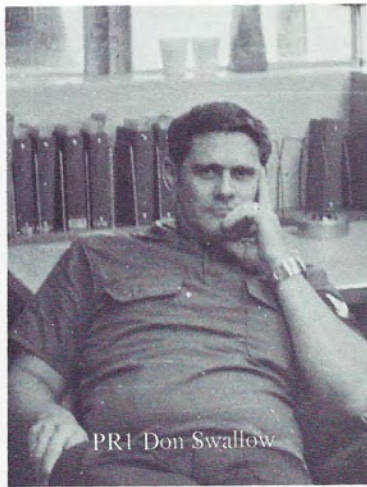

PR1 Don Swallow



AZ2 Maranon



AN-D. Baughman

Maintenance Control

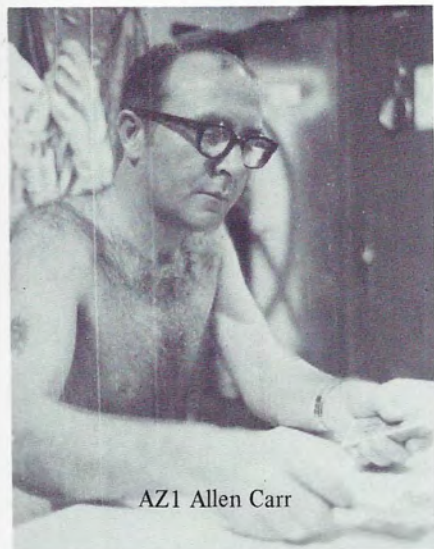

AZ1 Allen Carr



ADCS John Pratt

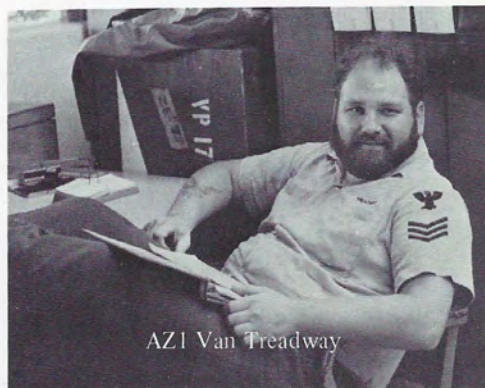

AZ1 Van Treadway



AZAA Nick Tamborino



ADJC Ron Schrader

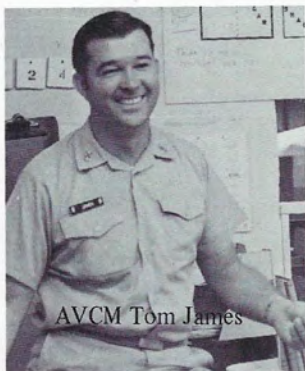

AVCM Tom James

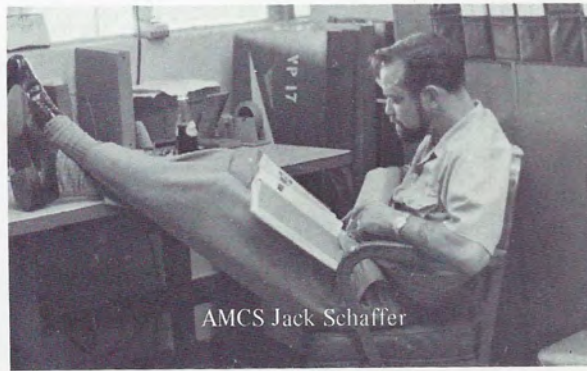

AMCS Jack Schaffer



ATC Marvin Miller



LT Daryl Ray

QUALITY ASSURANCE



ADJH Antonio Cruz



LT Mike Lauerman



ADI Craig Sharp

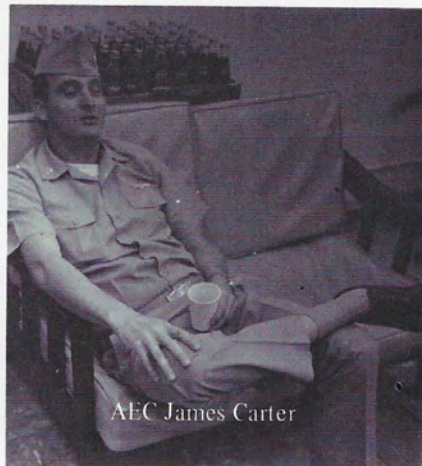

AEC James Carter



AMSC Jerry Long



AME 3 Steve King

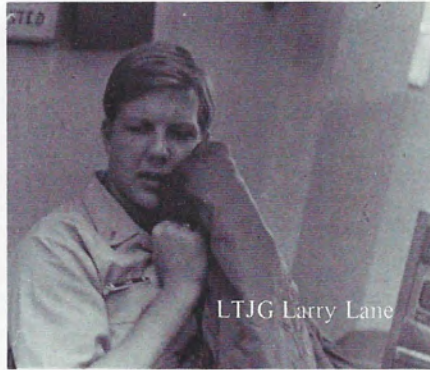

LTJG Larry Lane

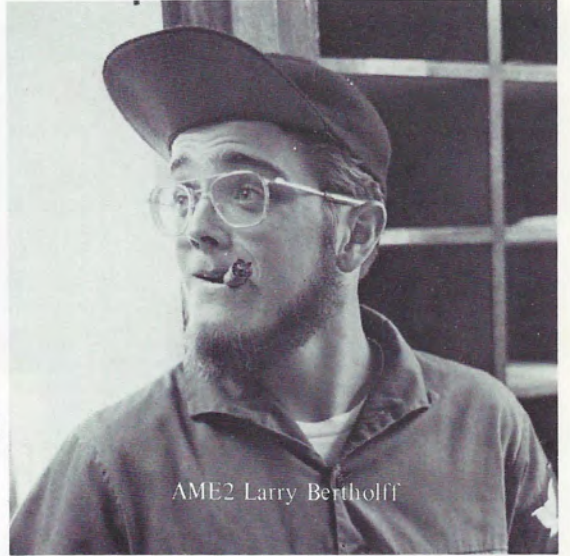

AME2 Larry Berthoff

AV/EQUIP

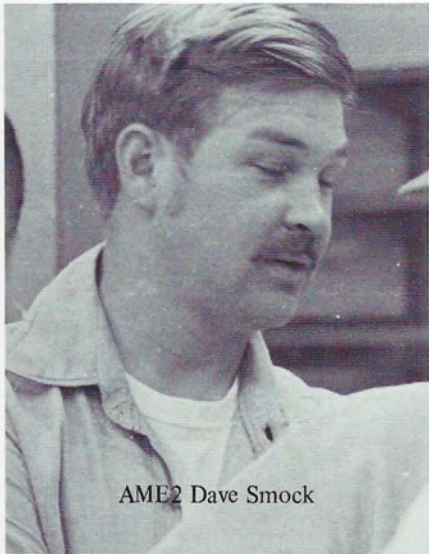

AME2 Dave Smock



PR3 Bruce Lysengen

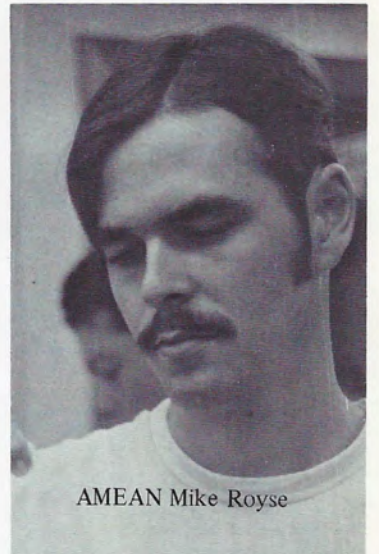

AMEAN Mike Royse

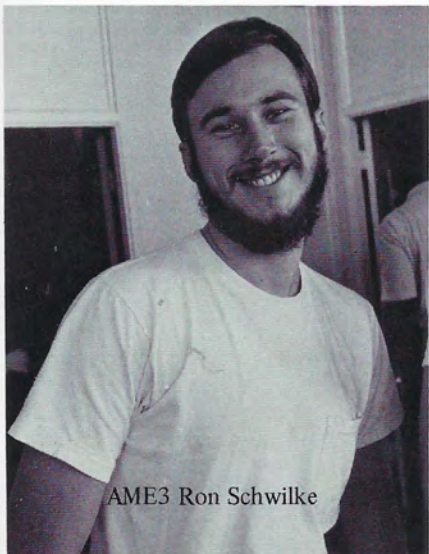

AME3 Ron Schilke

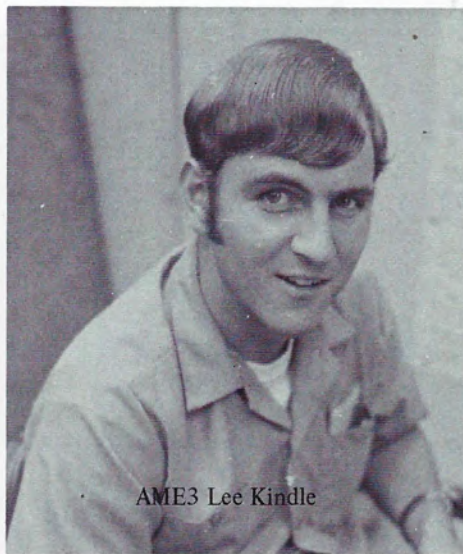

AME3 Lee Kindle



AME2 Garrett Hutchison

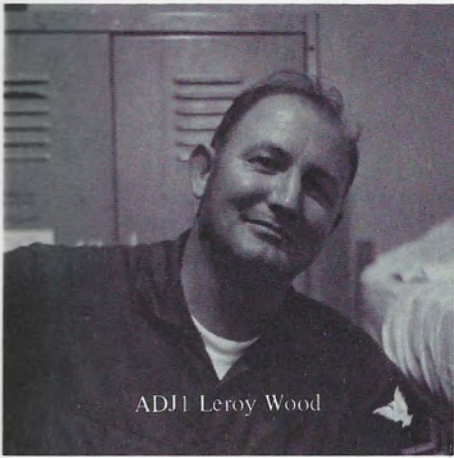

ADJ1 Leroy Wood



ADJ2 Dan Frankel

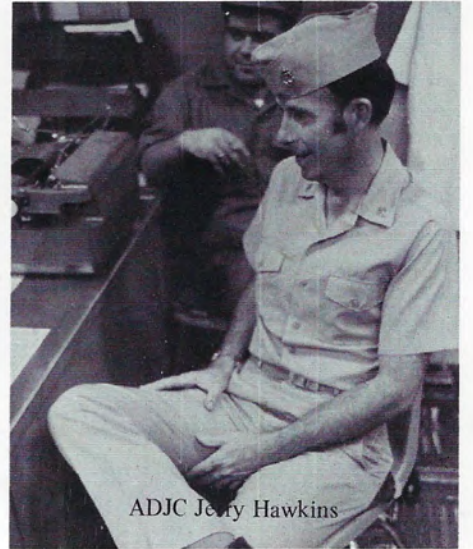

ADJC Jerry Hawkins

Power Plants

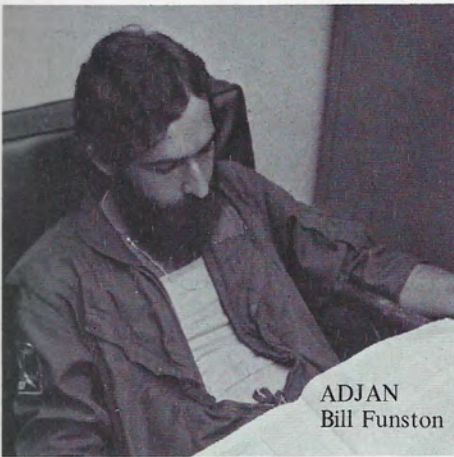

ADJAN
Bill Funston



ADJAN Jeff May



ADJ3 Nick Russo



AA Bob Waida

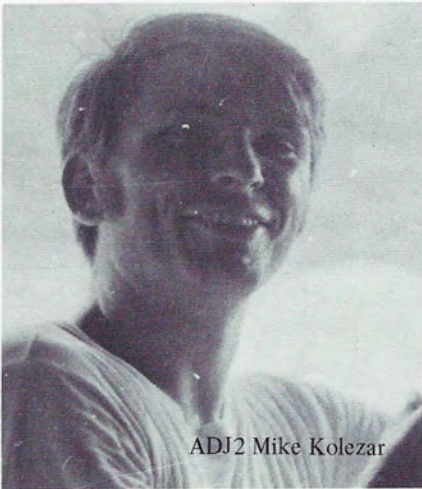

ADJ2 Mike Kolezar

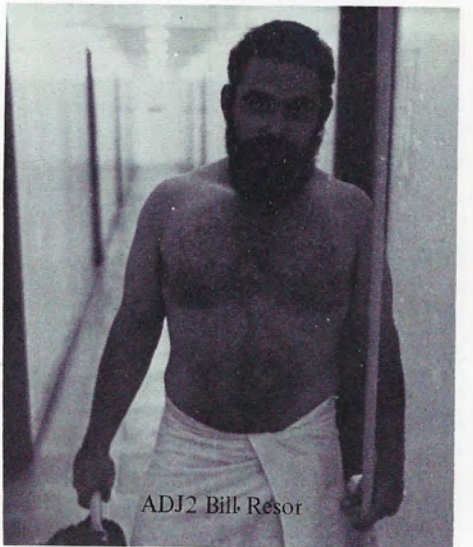

ADJ2 Bill Resor



ADJAN Roger Cloyd



ADJ3 Bob Watson

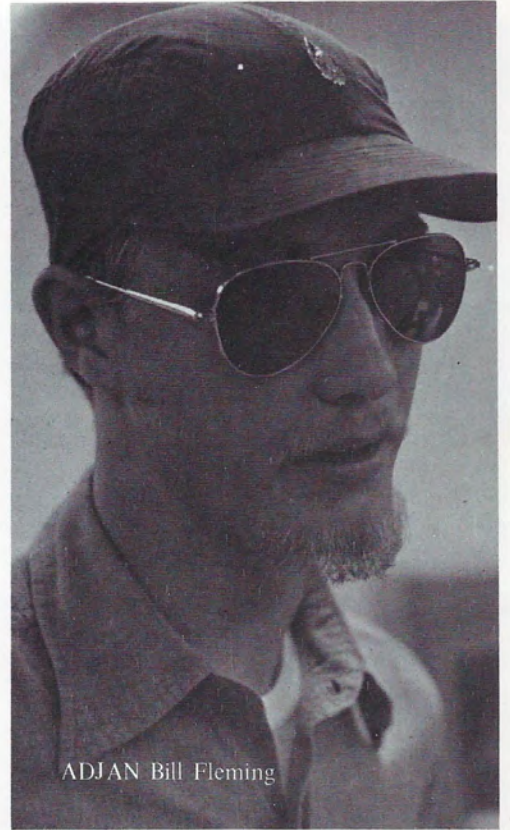

ADJAN Bill Fleming

POWER PLANTS



ADJAN Armando Bustamante

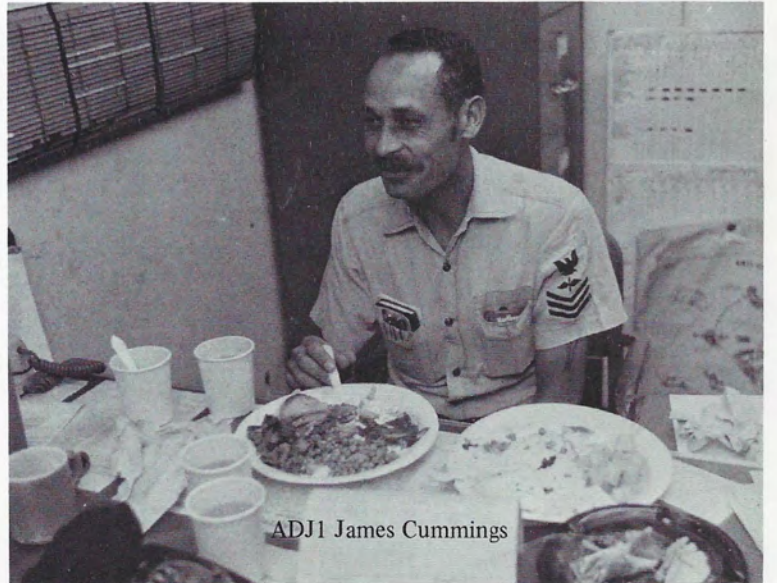

ADJ1 James Cummings



LTJG Bill O'Brian

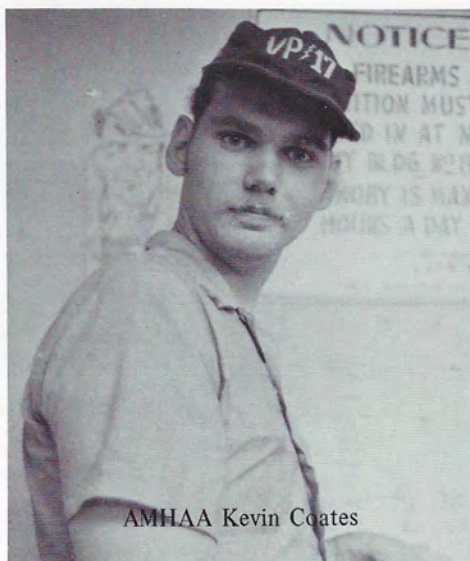

AMHAA Kevin Coates



AMS3 Jerry Devore

Air Frames



AMS2 Ron Fansler

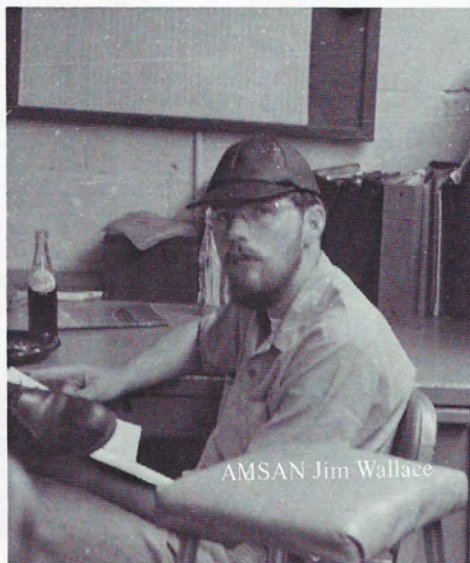

AMSAN Jim Wallace



AMH3 Ken Farquhar

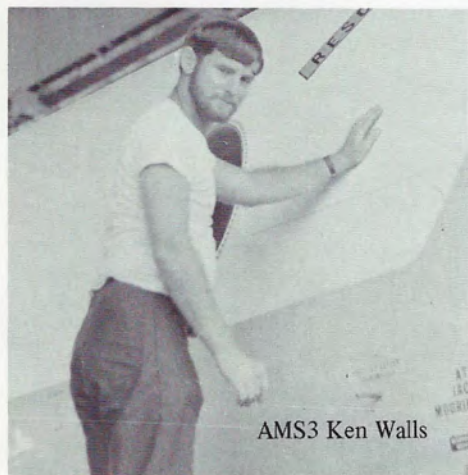

AMS3 Ken Walls



AMS1 Bill Matlock

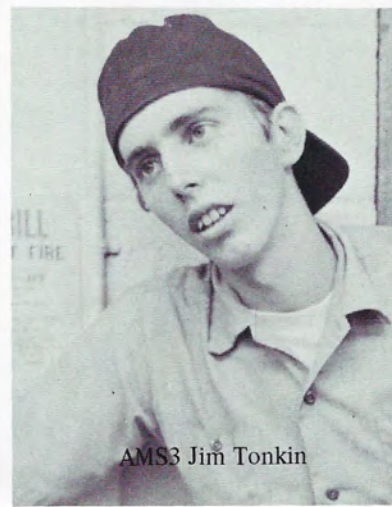

AMS3 Jim Tonkin

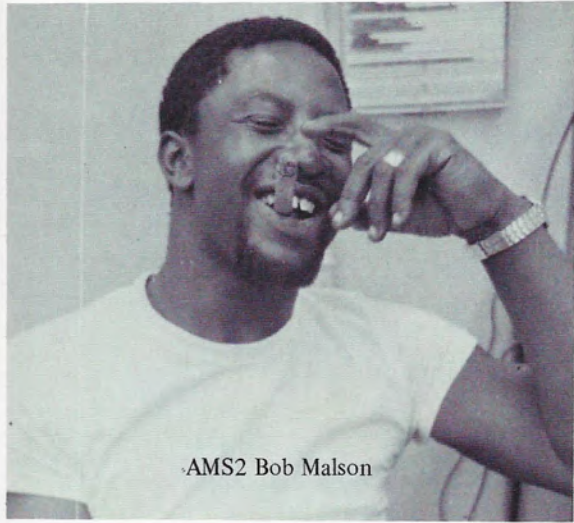

AMS2 Bob Malson

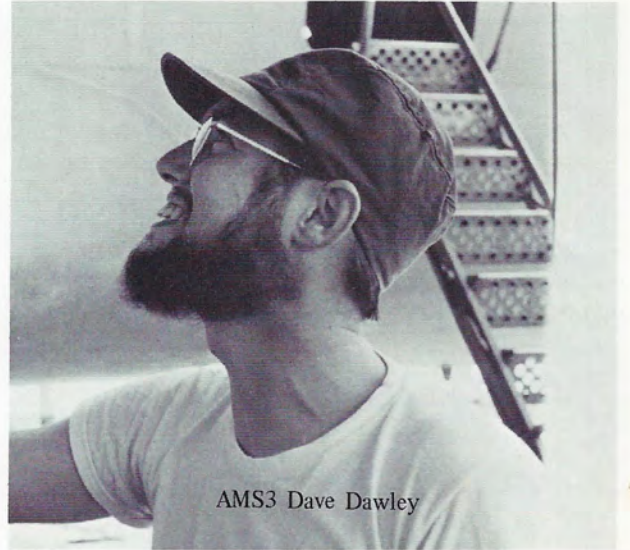

AMS3 Dave Dawley

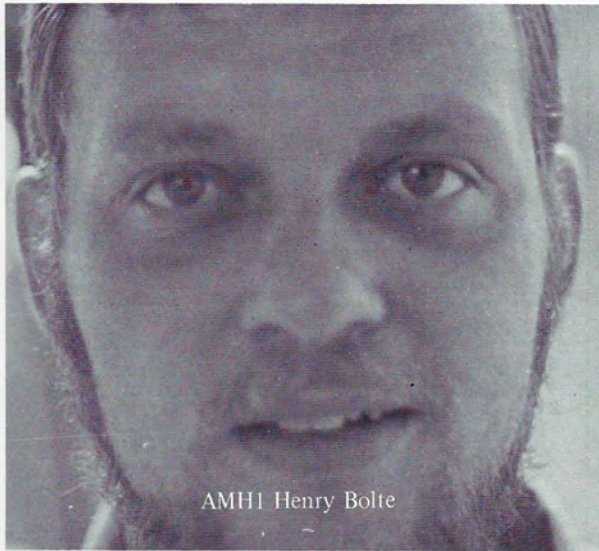

AMH1 Henry Bolte

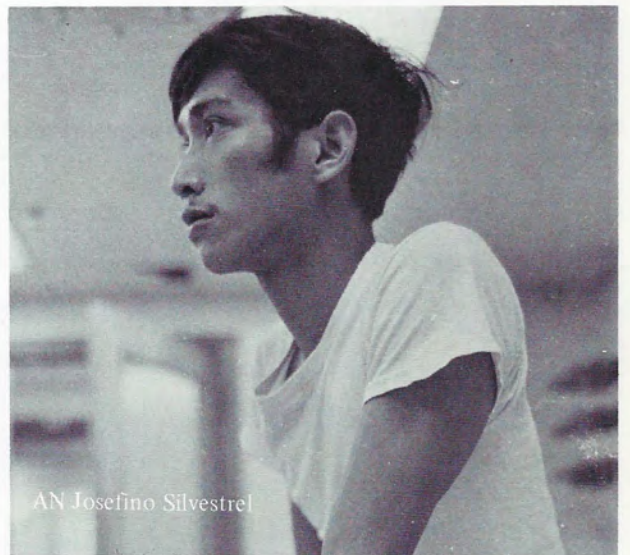

AN Josefino Silvestrel

A
A
R
F
R
A
M
E
S



AMS3 Dan Sharp



AMS3 Dick Lesco

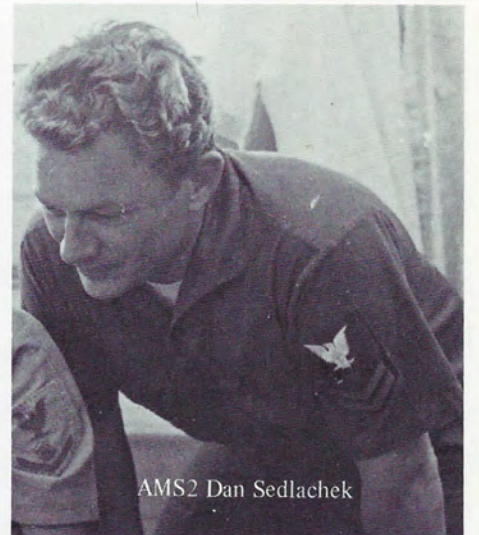

AMS2 Dan Sedlachek

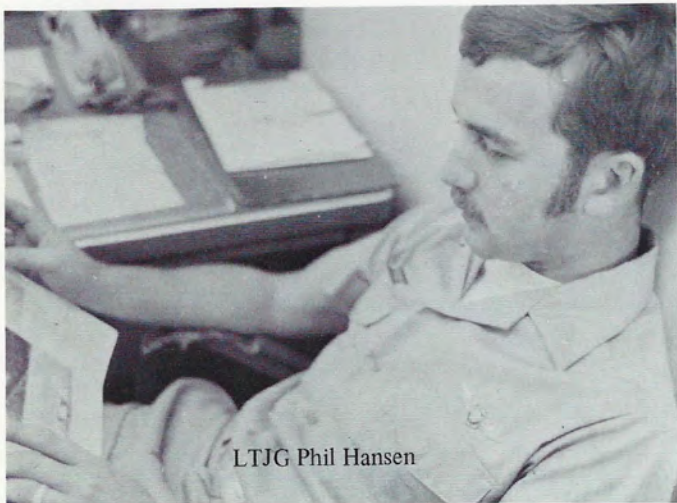

LTJG Phil Hansen

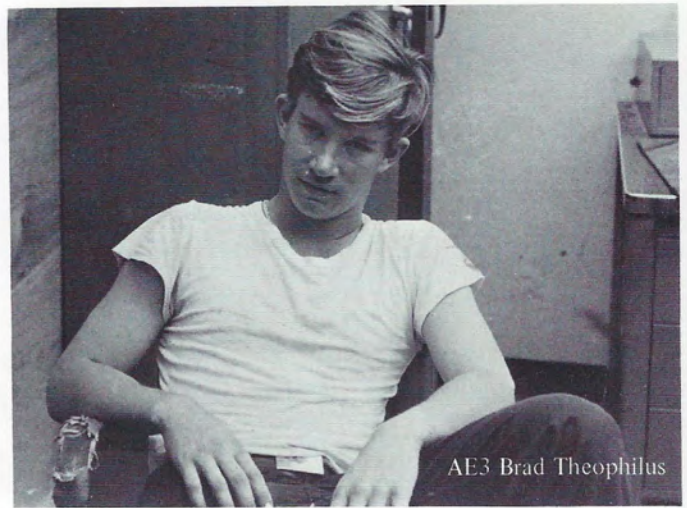

AE3 Brad Theophilus

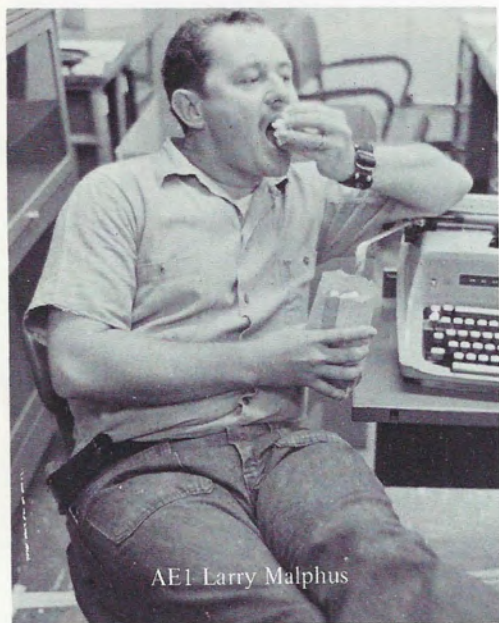

AE1 Larry Malphus

ELEC

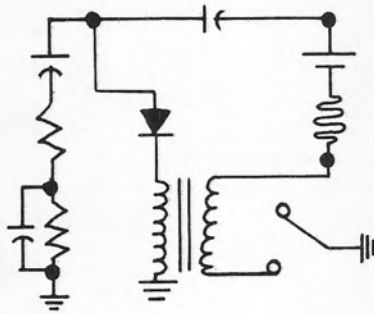

SHOP

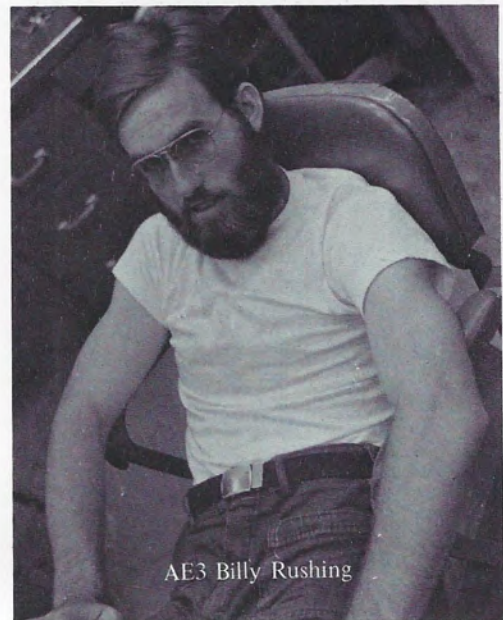

AE3 Billy Rushing

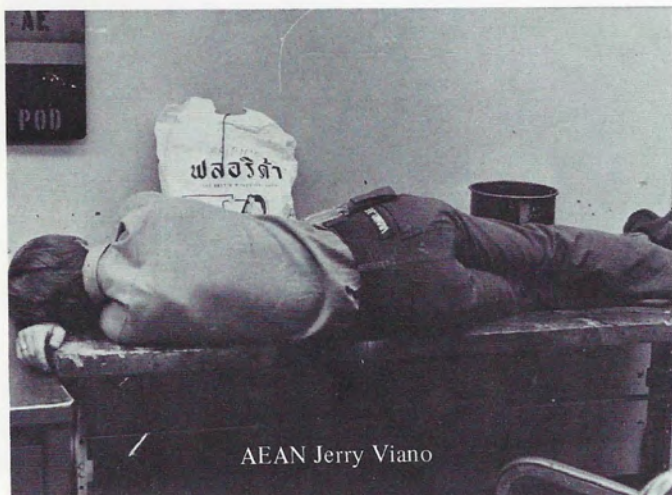

AEAN Jerry Viano

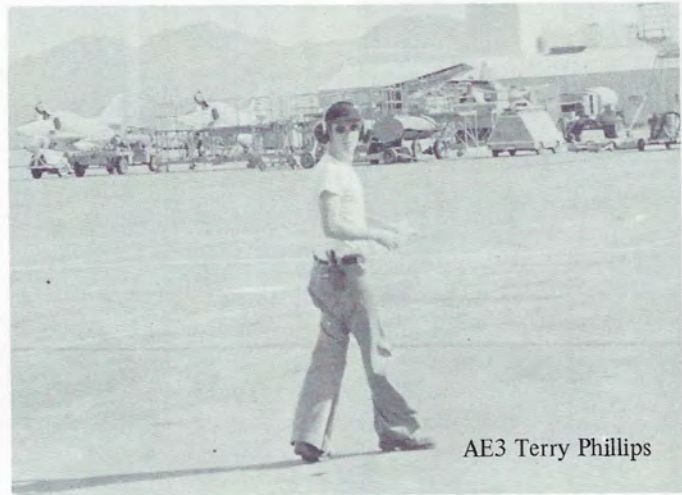

AE3 Terry Phillips



AOAN Mike Folloso

A vertical logo consisting of a bomb shape with a tail fin at the top and a pointed bottom. Inside the bomb, the letters 'O', 'R', and 'D' are stacked vertically in a bold, sans-serif font.



AO1 Nelson Harper



AO3 Terry Stommes



AOAA Bob Gerth

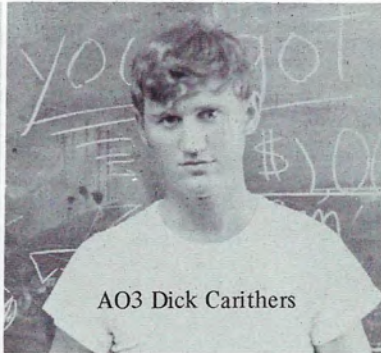

AO3 Dick Carithers

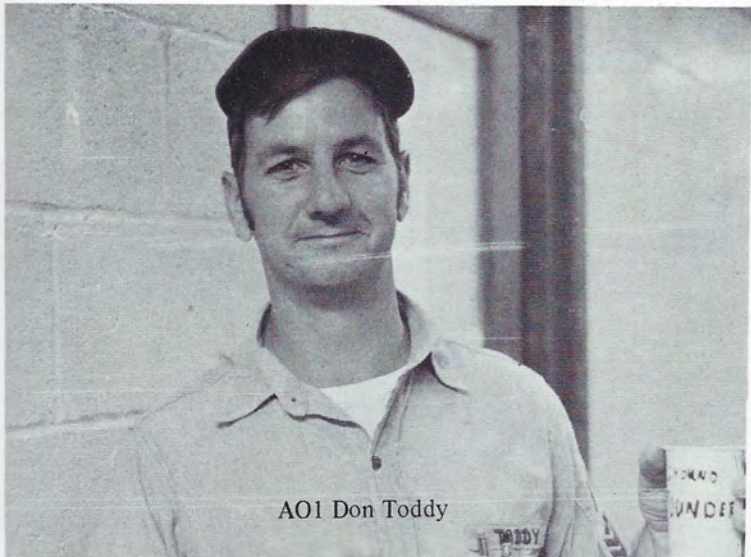

AO1 Don Toddy

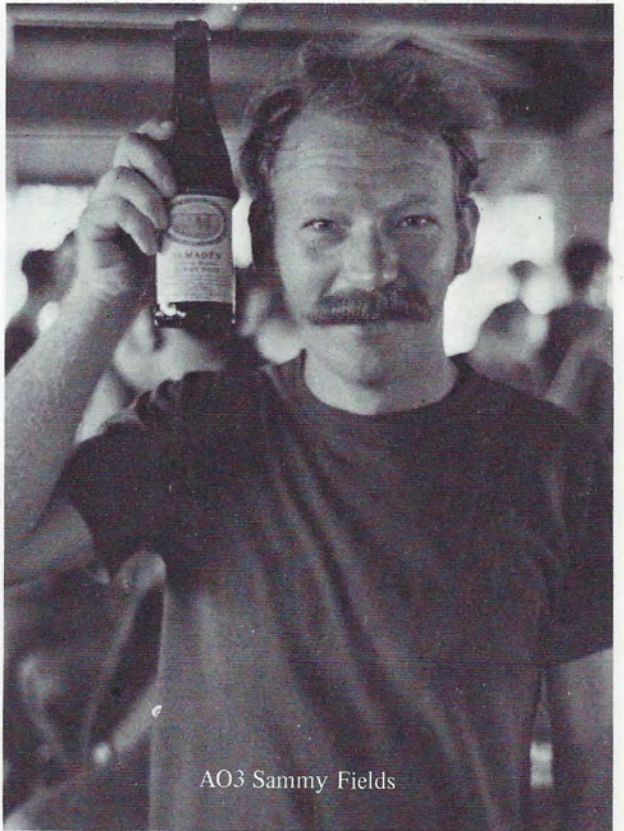

AO3 Sammy Fields



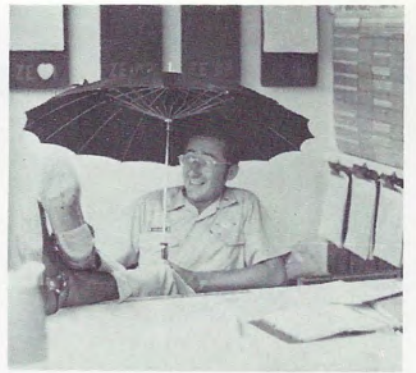

AT's

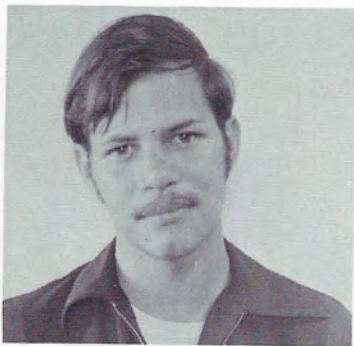



ADJC Bob Gerster

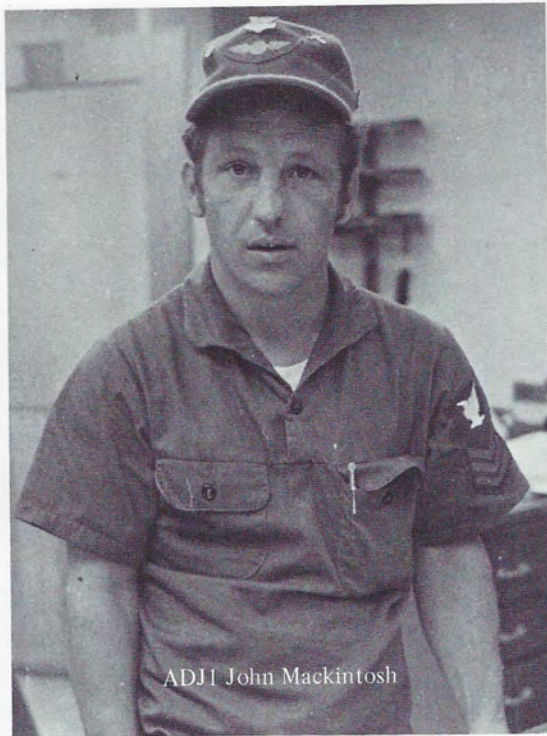

ADJ1 John Mackintosh

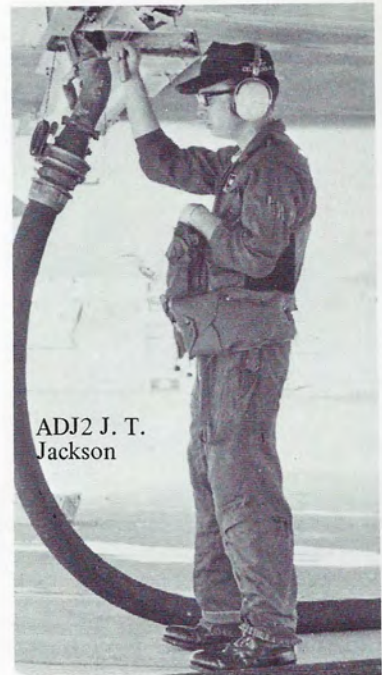

ADJ2 J. T. Jackson

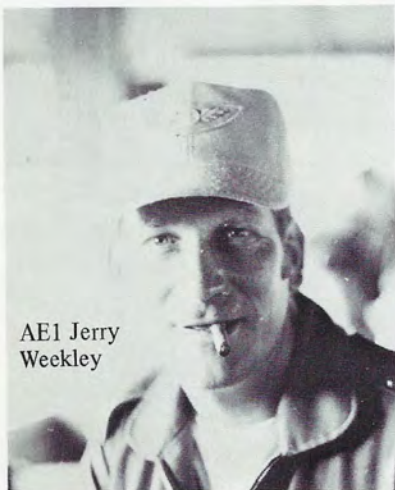

AE1 Jerry Weckley

Flight Engineers



AMH1 Ray Reed

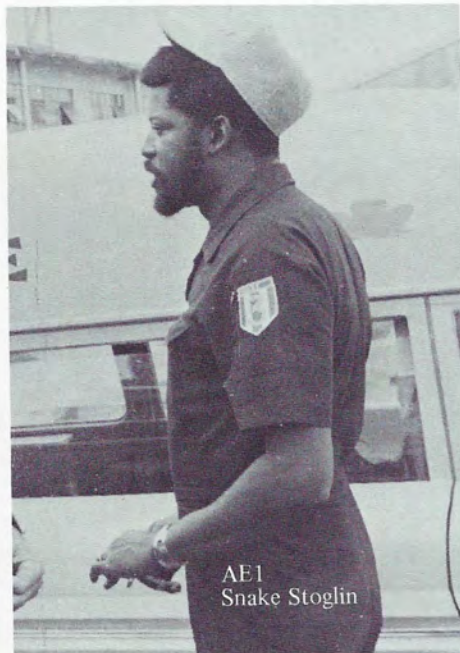

AE1 Snake Stoglin



AMS1 Mel Washburn

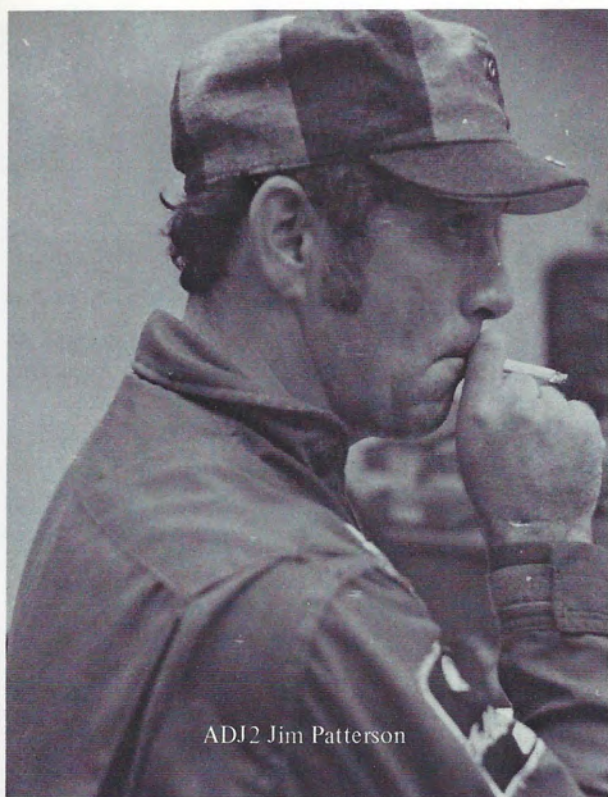

ADJ2 Jim Patterson

F/E

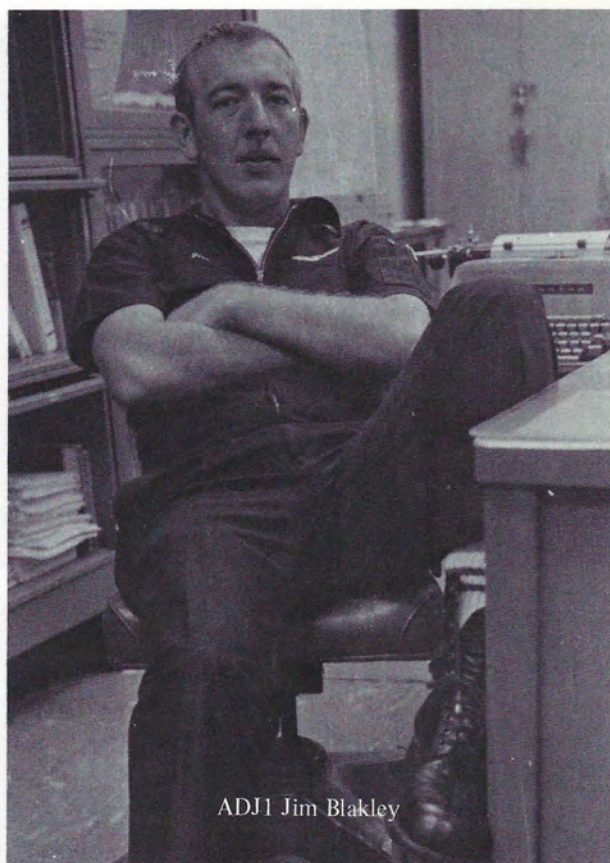

ADJ1 Jim Blakley

F/E



AMH2 Chuck Collett

F/E



ADR2 Carl Brown

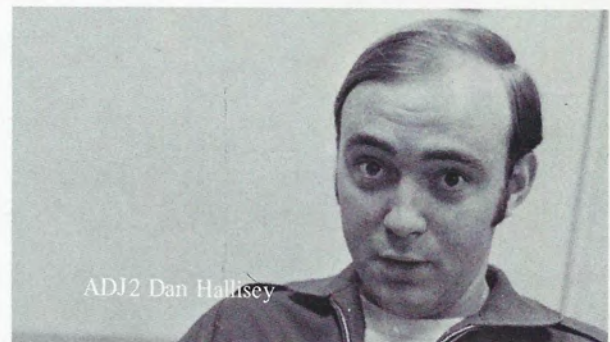

ADJ2 Dan Hallisey

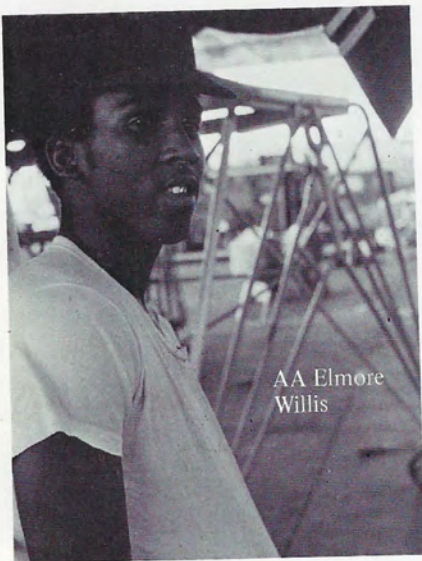

AA Elmore Willis

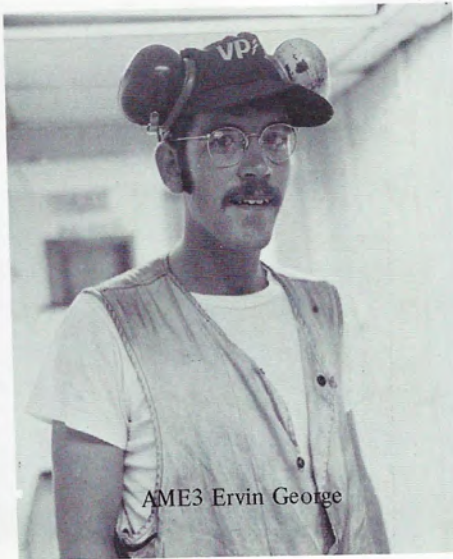

AME3 Ervin Geotge

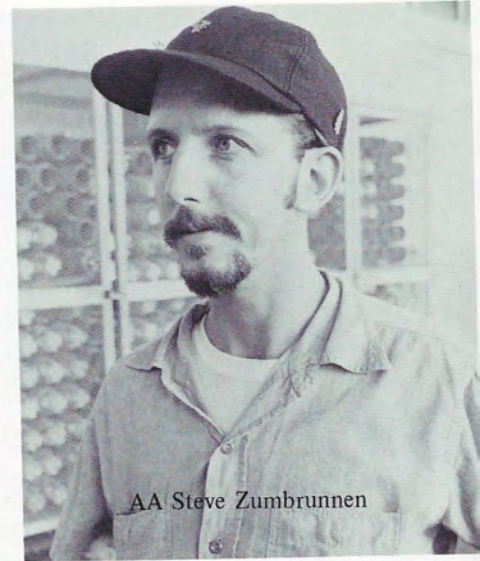

AA Steve Zumbrunnen



AN Paul Blackman

Line

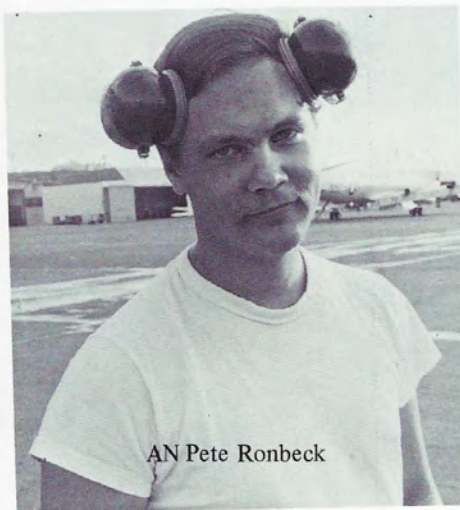

AN Pete Ronbeck

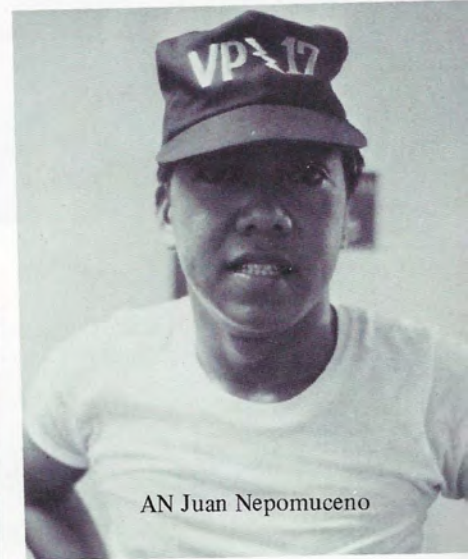

AN Juan Nepomuceno



ADJAN John Ball

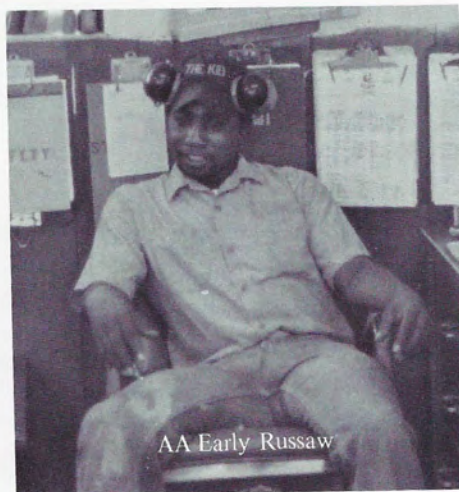

AA Early Russaw



AA Willard Stalker



AWAA Terry Hall

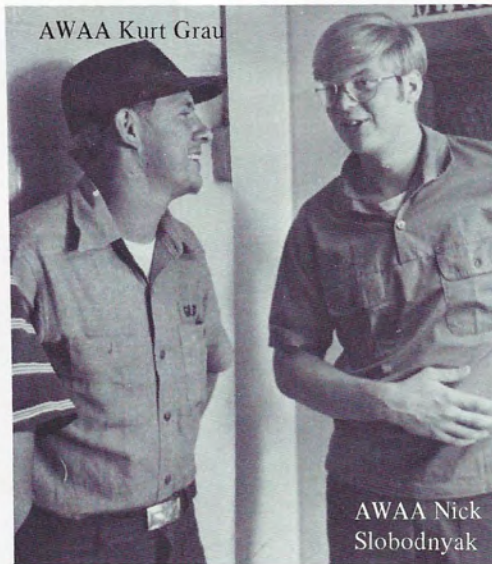

AWAA Kurt Grau

AWAA Nick Slobodnyak



AWCM Matt Bonnett

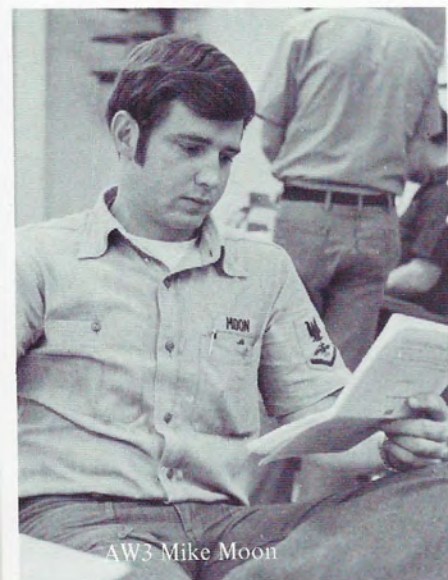

AW3 Mike Moon

AW BRANCH

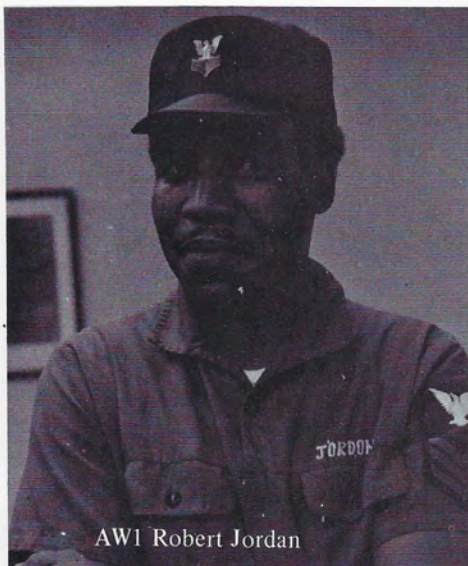

AW1 Robert Jordan

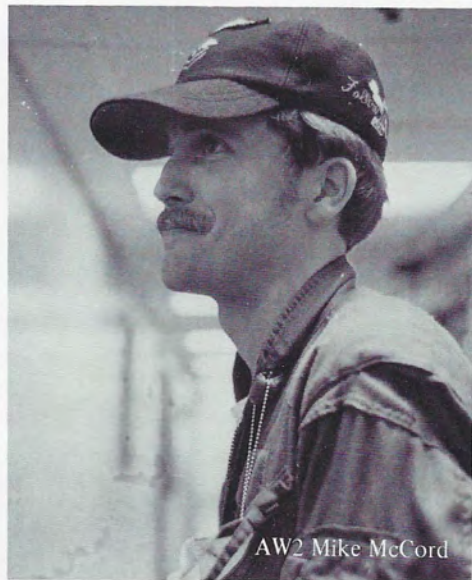

AW2 Mike McCord



AW2 Bill Poteet

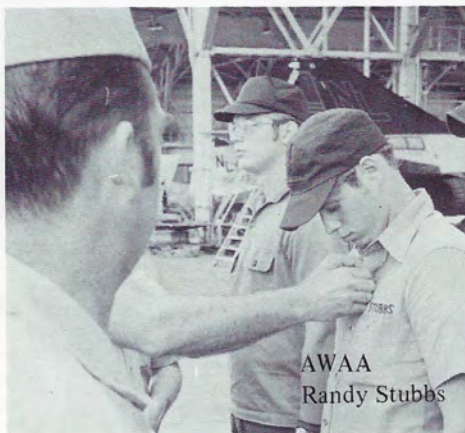

AWAA Randy Stubbs

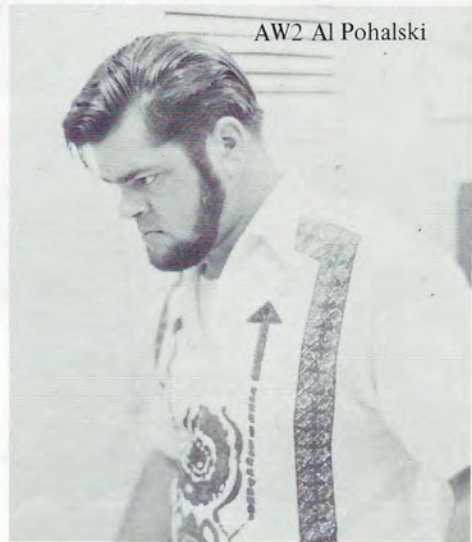

AW2 Al Pohalski

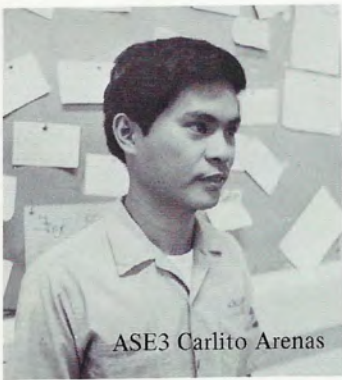

ASE3 Carlito Arenas



AMS3 Bob Howell

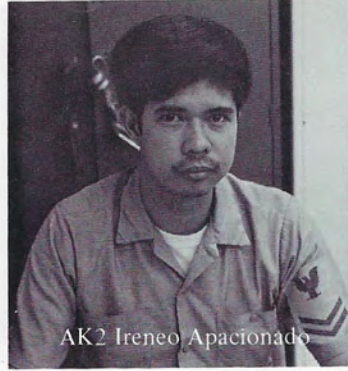

AK2 Ireneo Apacionado

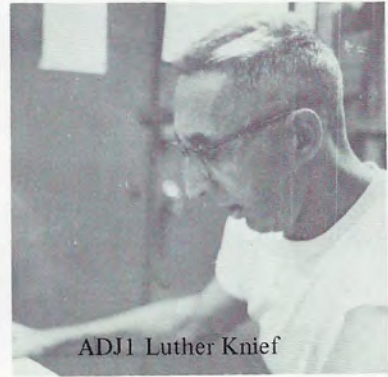

ADJ1 Luther Knief

TAD Personnel

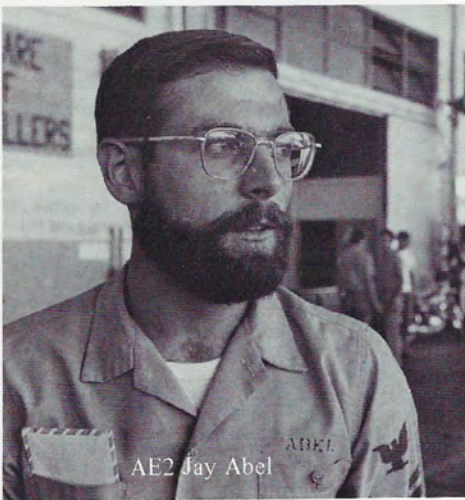

AE2 Jay Abel



AE3 Bob Vzzell

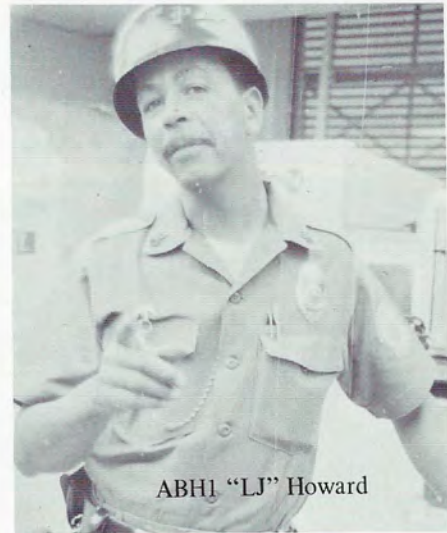

ABH1 "LJ" Howard

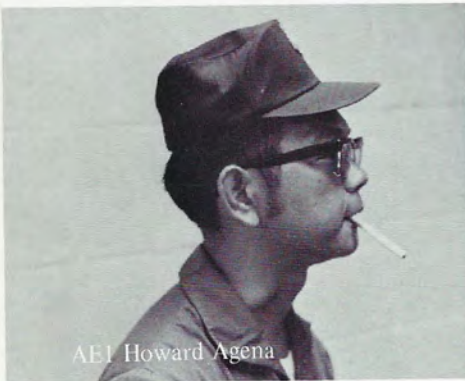

AE1 Howard Agena

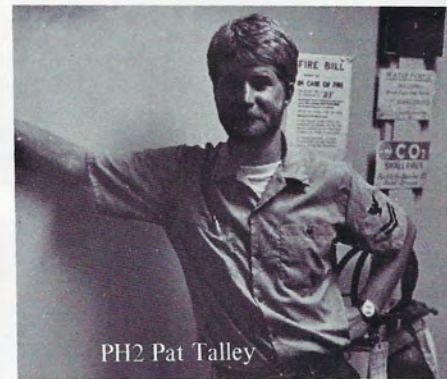

PH2 Pat Talley



PH2 Doug Siefkin

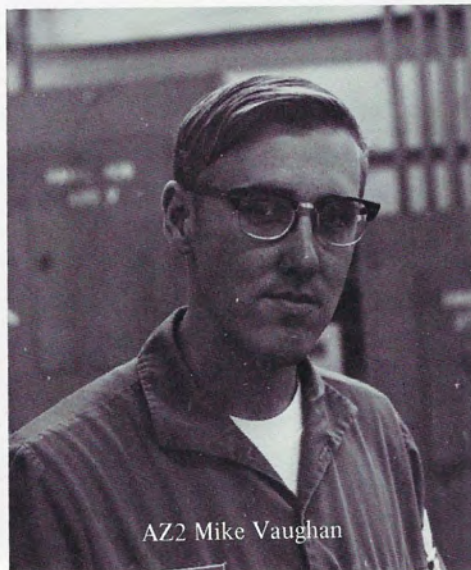

AZ2 Mike Vaughan



SD3 Ben Ngoslab

PATRON 17



FLIGHT CREWS

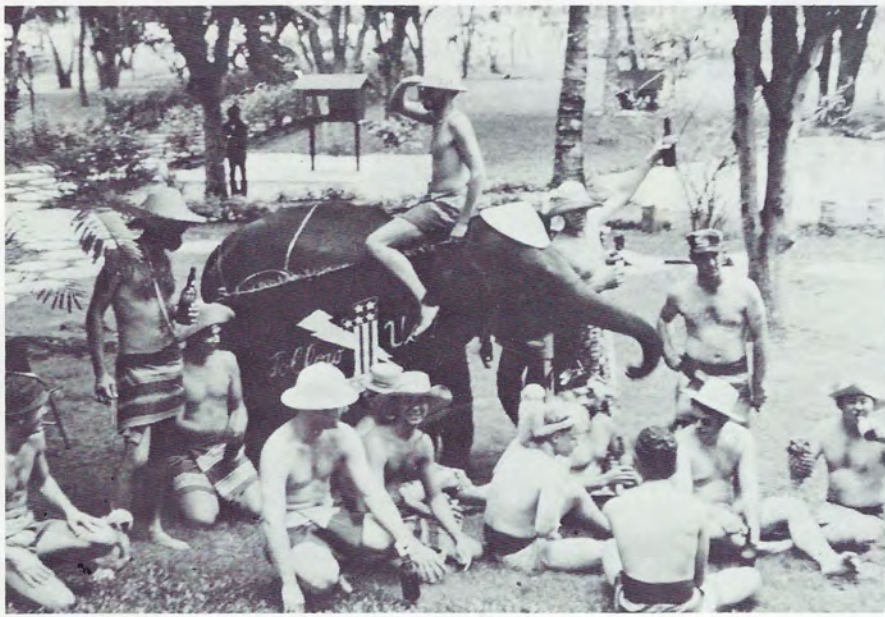

PPC LT Gerry Spaulding
 C/P LTJG Pete Magoun
 C/P LTJG Jim Carlson
 TACCO LT Bob Barclay
 NAV LTJG Bob Brooks
 F/E ADJ2 James Patterson

F/E AMH1 Gary Davidson
 SS1 AW1 Sid Hanisee
 SS2 AW2 Michael McCord
 ORD AO3 Terrance Stommes
 RDO AT3 Ken Miller
 INFLT TEK AT1 Frank Steineke
 2nd MECH ADJAN William Funston



Follow Us!





PPC LCDR Mike McBride
 PPC LT John Rowbottom
 C/P LTJG Bill Blase
 TACCO LT Steve Peck
 NAV ENS George Vogel
 F/E AMS1 Ray Washburn
 ORD AO1 Don Toddy

2M ADJAN Moses Bustamante
 SS1 AWAN Tom Wallace
 SS2 AW3 Steve Story
 SS3 AW2 John Lee
 RDO ATAN Gary Kindle
 IFT AX2 Harold Bartlett
 ORD AOAN Michael Follosco

**CREW
TWO**

*Hot Damn &
Boy Howdy*

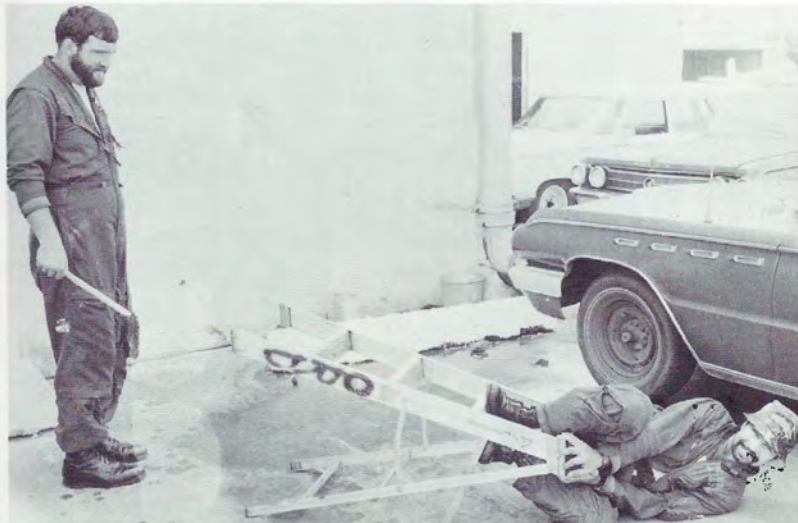
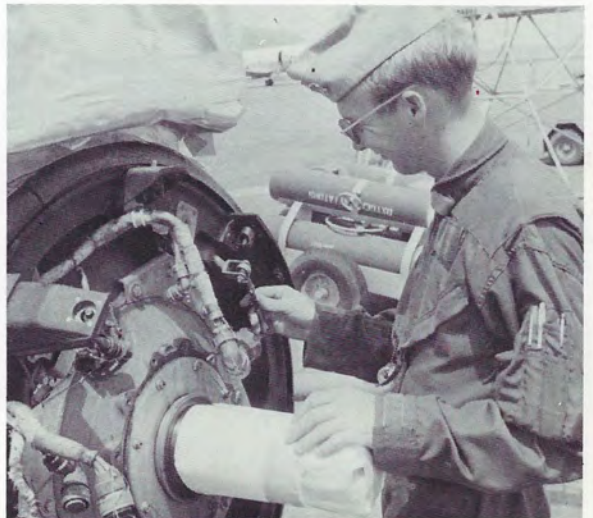



PPC LCDR Larry Croll
 PPC LT Steve Vaughn
 C/P LTJG George Anderson
 TACCO LT Paul Holder
 NAV LTJG Harley Schreck
 F/E AE1 "Snake" Stoglin

2M ADJAN William Fleming
 SS2 AW2 Joseph Winans
 SS2 AWAN James Walden
 SS3 AWAN Terry Hall
 RDO AT3 Michael Bressler
 IFT AT1 Bill Schrage
 ORD AA Douglas Whittecar



THREE



CREW 4

PPC — CDR Bill Ketchum
 C/P — CDR Guy Rettig
 TACCO — LCDR Dallas Lundquist
 NAV — LTJG Frank Mikusi
 F/E — AECS James Carter
 F/E — ADRC Jack Schrage
 SS1 — AWC Willis Stagner
 SS2 — AWC Matthew Bonnet
 RDO — AT1 Bill Davis
 ORD — AT1 Benny Simmons





CREW FIVE



- PPC LT Jim Humphrey
- C/PPC Denny Hackathorn
- C/P LTJG Steve Root
- C/P LTJG Don Phillips
- T/C LTJG Bill Overend
- NAV LTJG Dave Larson
- F/E AMS1 Bill Calder
- 2M AMS2 Ron Fansler
- SS1 AW3 Glenn Mueller
- SS2 AWAN Neal Bodell
- RDO ATAN John Fanning
- IFT AX2 Ron Raper
- ORD AO3 Sammy Fields



CREW SIX

PPC – LCDR Jack Williams
 C/P – LTJG Dave Norris
 NAV – LTJG Mike Bangert
 Tacco – LTJG Sam Stevinson

F/E – AE1 Paul Dudley
 2M – ADJ3 Steve Wilson
 SS2 – AW2 Mark Hill
 ORD – AO3 Mike Steffans

SS1 – AWAN Fred Bruce
 RDO – AXAN Max Gibson
 IFT – AT3 Bob Dyer

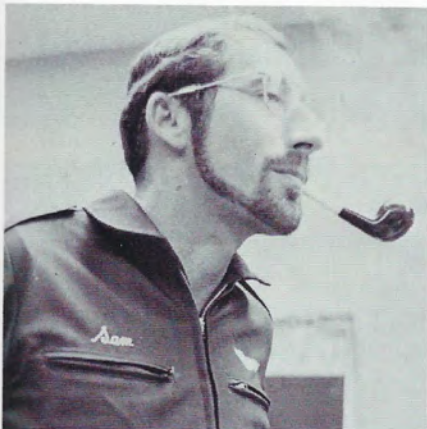

PPC Bill Boyd
 PPC LT Ted Morrison
 C/P LTJG Bill Buckingham
 C/P LTJG Dan Straus
 TACCO TL Ray Laturno
 NAV LTJG Glenn Knechtel
 F/E AMH1 Ray Reed
 2M ADJ2 J. T. Jackson
 RDO AX3 Jimmy Hamilton
 SS1 AWAN Kurt Grau
 SS2 AW2 Bill Bean
 SS3 AW1 Steve Davis
 ROD AO3 Daylon Royal
 IFT AT3 Harry Keeling



WE HAVE ALREADY

BEEN THERE



CREW EIGHT



PPC – LT Greg Bushnell
PPC – LT Ken Crandall
C/P – LTJG Mark Ziemendorf
TACCO – LT Jim McGroarty
NAV – LTJG Jon Dresel
F/E – AE1 Jerry Weekley

F/E ADJ2 Dan Hallisey
SS1 – AW1 Mike Jones
SS2 – AW3 Allen Pohalski
SS3 – AW3 John Kylo
RDO – AT3 Mike Morgan
IFT – AT1 Mike Rigby
ORD – AO2 Don Collette



IX



PPC – LT Warren Traub
 PPC – LT Daryl Ray
 2P – LTJG Phil Hansen
 3P – LTJG Larry Lane
 TACCO – LT Paul Sanger
 NAV – LTJG Bill O'Brien
 F/E – AMH2 Chuck Collett

2M – ADJAN Roger Cloyd
 ORD – AO1 Nelson Harper
 RDO – AT3 Gary Melendez
 SS3 – AW1 Ray Jordan
 SS2 – AWAN Steve Coots
 SS1 – AWAN Randy Stubbs
 IFT – AT1 John Mochlankamp



CREW TEN

PPC LT Mark Byars
 C/P LT Doug McWhorter
 3P LTJG Leo Dete
 TACCO LT Bob Scruggs
 NAV LTJG John Wise
 F/E ADJ2 Robert Hancock

2M AEAN Jerry Viano
 SS1 AW3 William Poteet
 SS2 AW3 Glen Wiley
 RDO AA Rodney Barber
 IFT AT3 Jack Ogg
 ORD AO2 Edward Alford



CREW ELEVEN



PPC — LCDR Jim Fields
 PPC — LT Pat Maley
 C/P — LTJG Harold Hyman
 NAV — LT "J. B." Carter
 2TC — LT Bob Richards
 F/E — ADJ1 Jim Blakley
 F/E — ADJ1 Mike Austin
 SS1 — AW3 Harvey Trotter
 SS2 — AWAN Francis Unabia
 RDO — ATAN Gary Fisher
 IFT — AT2 Frank McAtee
 ORD — AO1 Ben Nettles

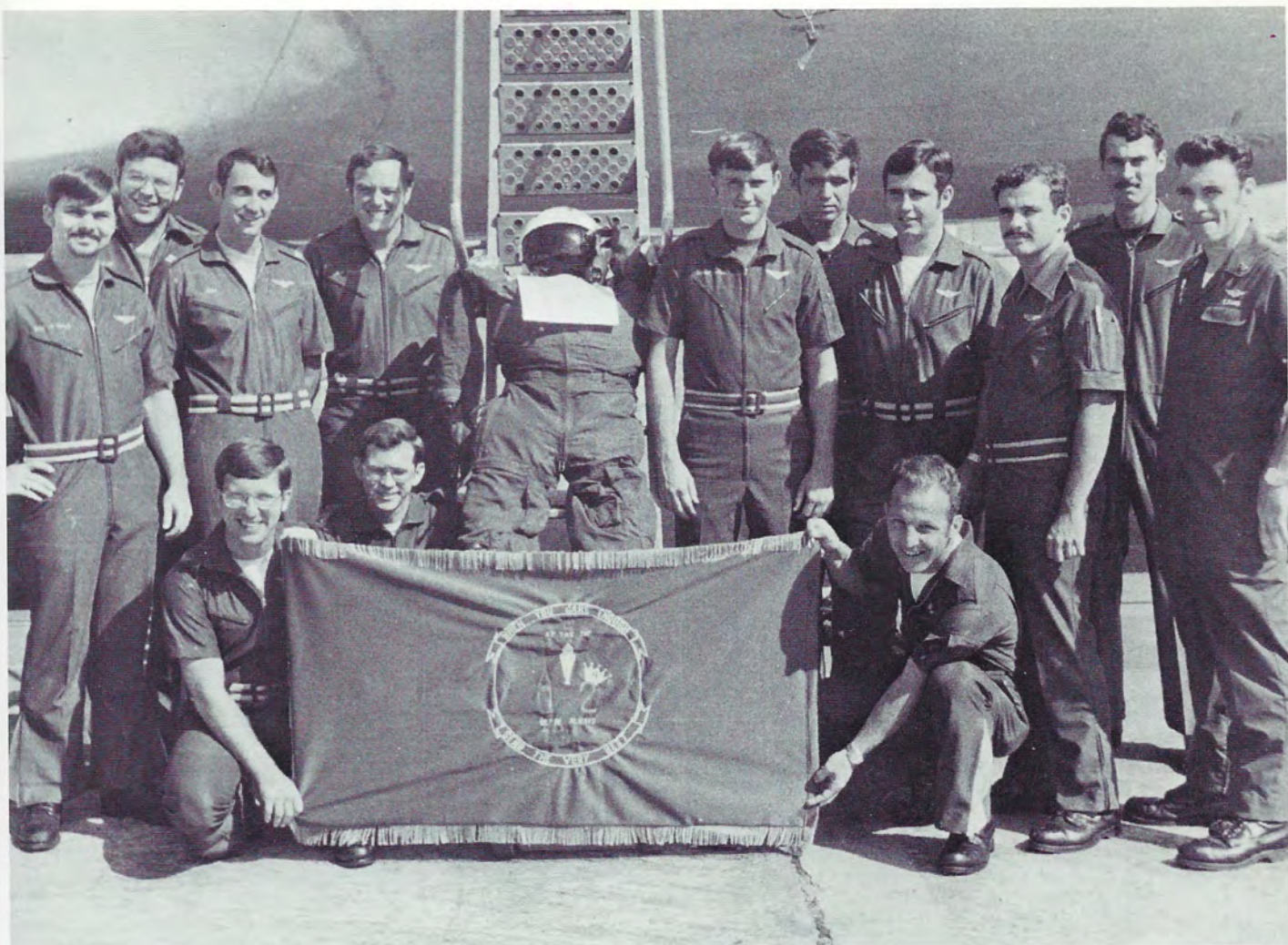

PPC LCDR Bill Vincent
 PPC LT Mike Lauermann
 3/P LTJG Bob Gastall
 TC LT Dudley Chase
 NAV ENS Tom Goen
 F/E ADJ1 John Mackintosh

F/E ADR2 Carl Brown
 SS1 AWC George Lyons
 SS2 AWAN C. L. Jones
 SS3 AW3 Mike Moon
 RDO ATAN W. J. Wadlington
 IFT AT3 Gary Watzig
 ORD AOAN Richard Carithers



CREW 12

TWELVE

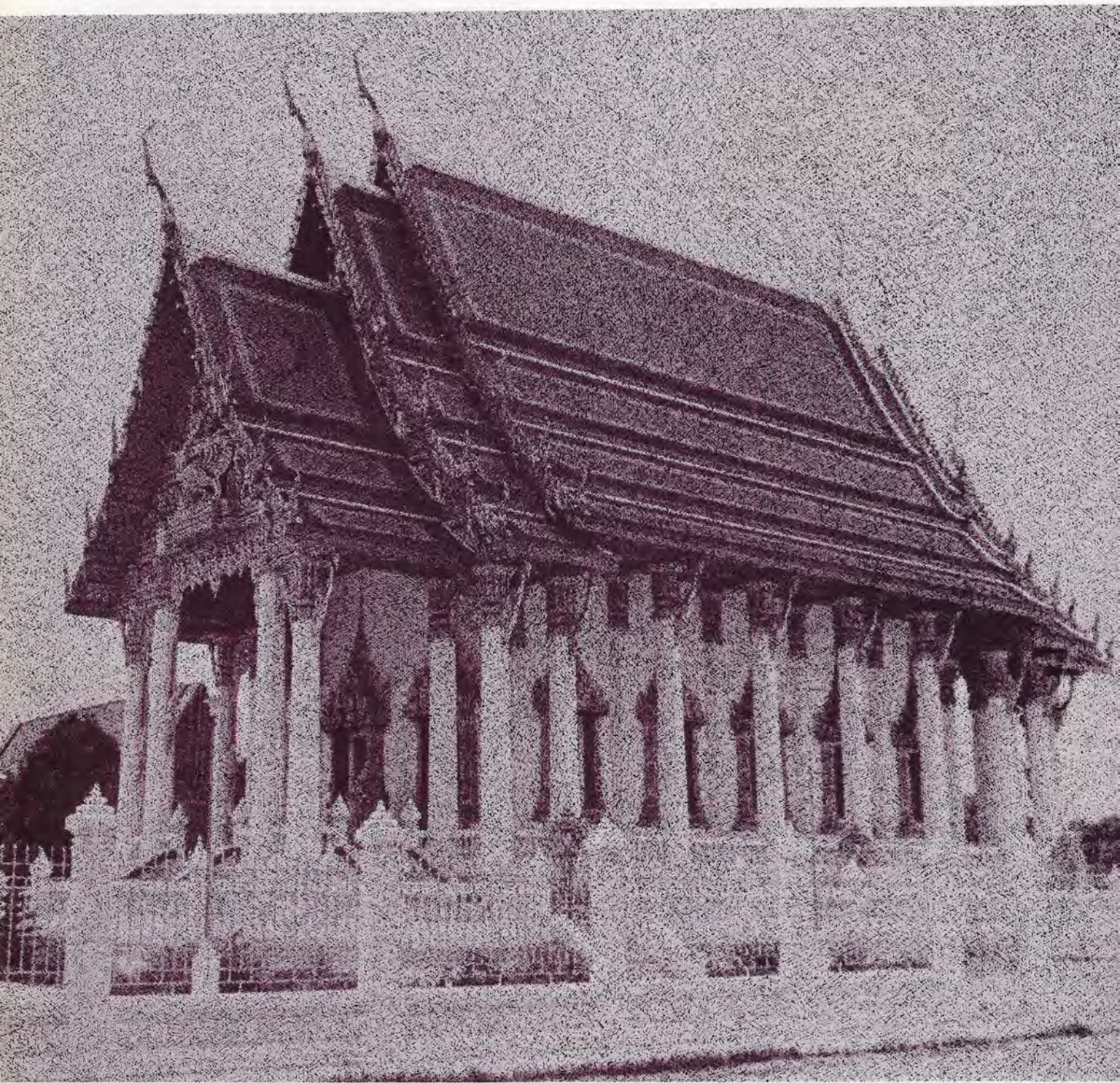



CSS4 Dave [unclear]



CSS4 Bob Cantul



CS1 David Lane

7AD Personnel

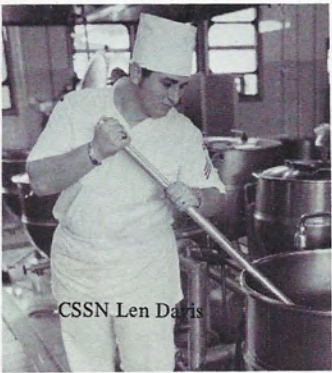

CSSN Len Davis

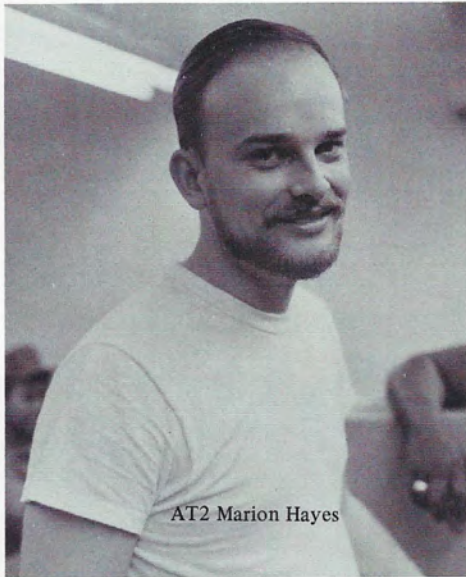

AT2 Marion Hayes

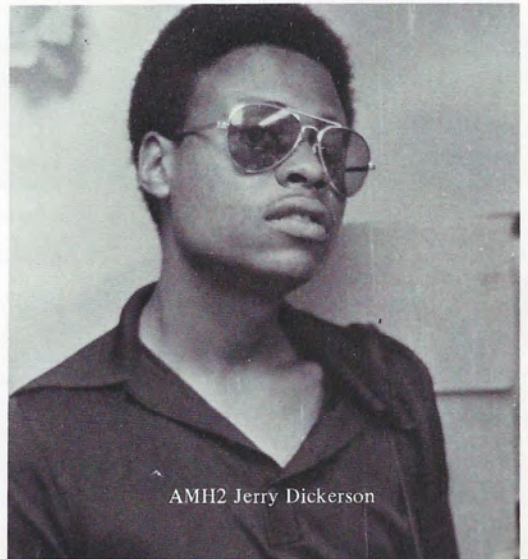

AMH2 Jerry Dickerson

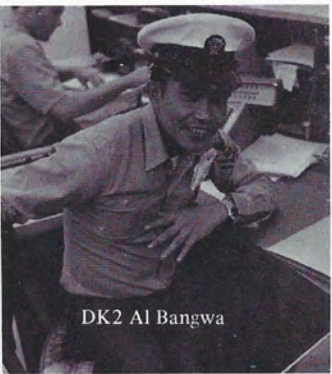

DK2 Al Bangwa

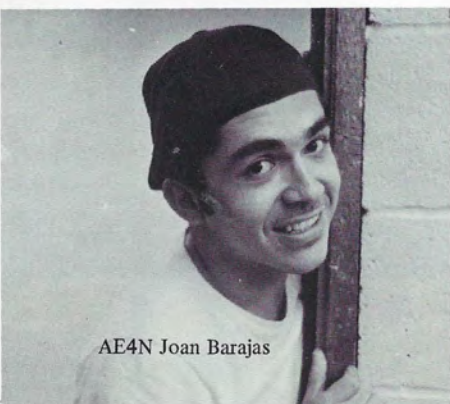

AE4N Joan Barajas

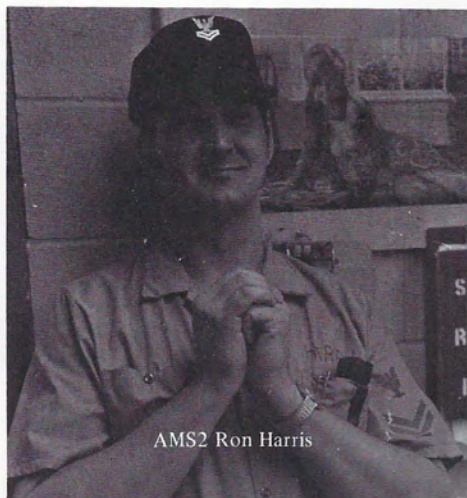

AMS2 Ron Harris

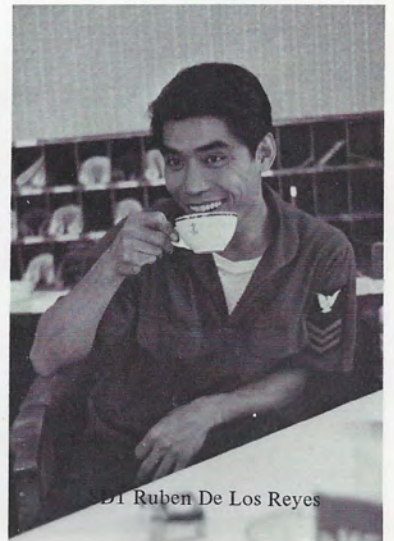

DI Ruben De Los Reyes

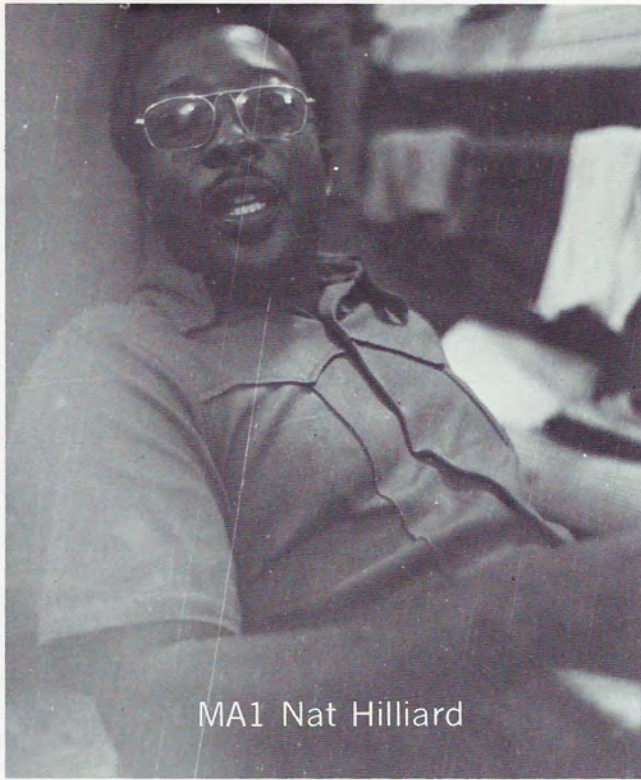

MA1 Nat Hilliard

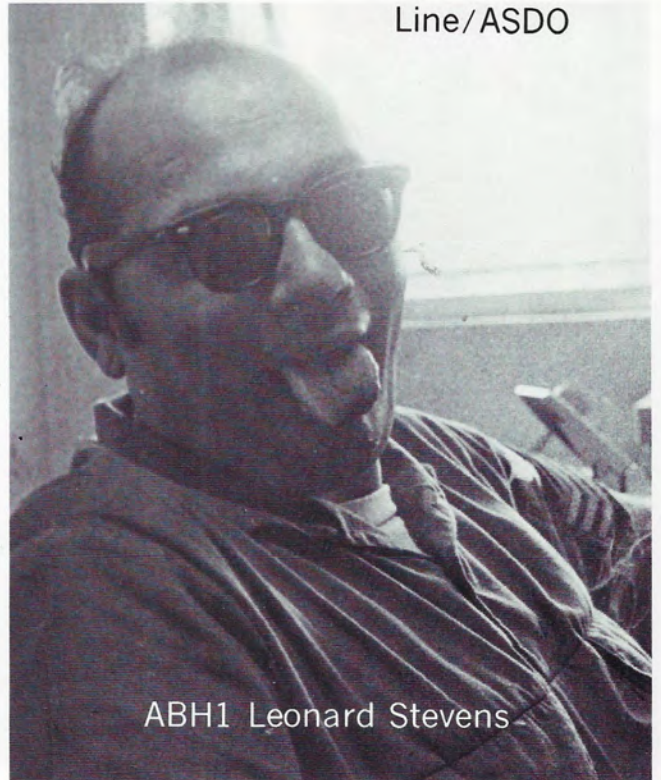

ABH1 Leonard Stevens



MA1 Charles Keller

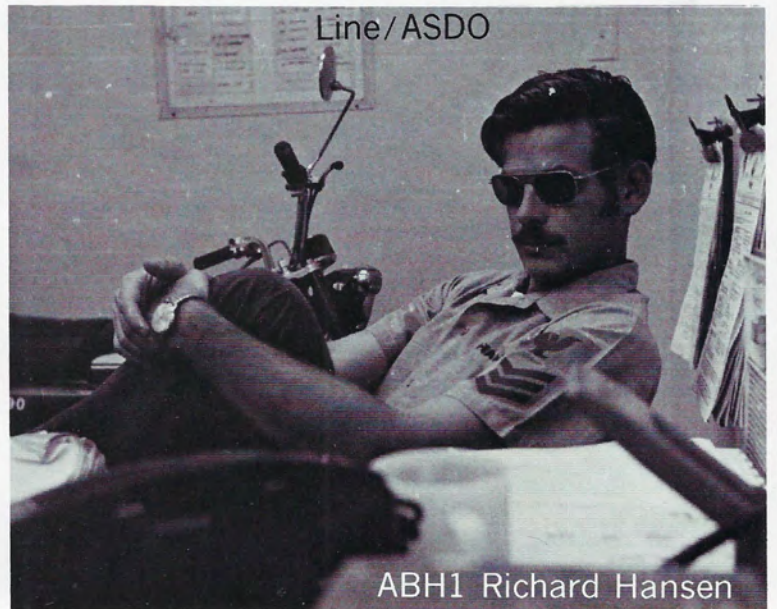

ABH1 Richard Hansen

YOU KNOW YOU BEEN IN THE P.I. TOO LONG WHEN:

You don't answer to Joe when your name is Joe
Your speech is marked by such expressions as "I'll have a Pepsi."
You think an umbrella is part of your Navy uniform
You are in a bar and two Filipinos walk in with loaded Thompson sub-machine guns, and you calmly sit and drink your beer
You can not remember what a bathtub looks like
You think a hot water faucet is just for decoration
You think a luxury hotel is one with a seat on the toilet
You'd rather sleep on a table in a bar than in the barracks
You tie a gekko to your rack to control mosquitos
You can't sleep on station because you miss the roosters
You clean the neck of your Listerine bottle before using it
You can open a "butterfly" knife onehanded without cutting your hand off
You save your good shower shoes for special occasions
You understand all the profanities the locals shout at you
You start shouting profanities at the locals – in Tagalog
Someone mentions the President and you think of Marcos
You get a roll of five centavo pieces so that jeepny drivers can't keep the change No matter how drunk you get, San Miguel still tastes good
You think of retiring here because you like the place and it's cheap
You crawl around the floor looking for the five centavo piece you dropped
You want to strangle every huk you see just for GP
You begin to treat every pig in the bars like a lady
You find it's more comfortable to squat than to sit
You think it's cold and it's 75° outside
You can eat a balut without throwing up
You'd rather eat fried fish than steak
You always eat rice instead of potatoes
You go to USO shows because you like them
You think five pesos is a lot of money
Stateside beer tastes funny

RE-ENLISTMENTS... PROMOTIONS ... ADVANCEMENTS ... FROCKING ... AWARDS ... ETC...

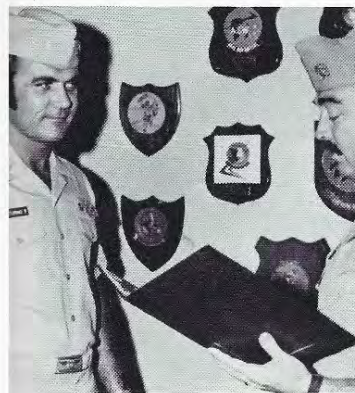
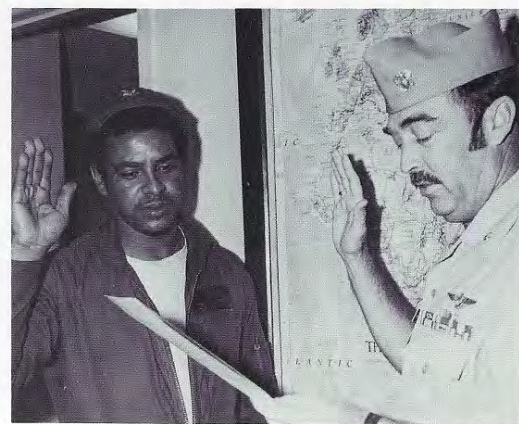
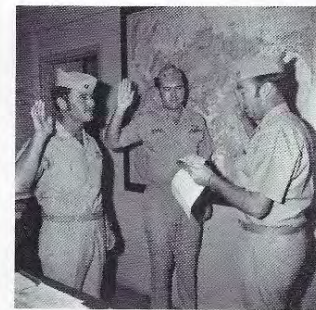
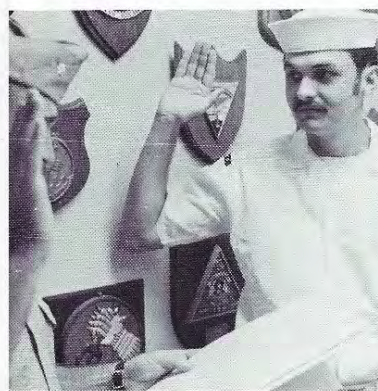
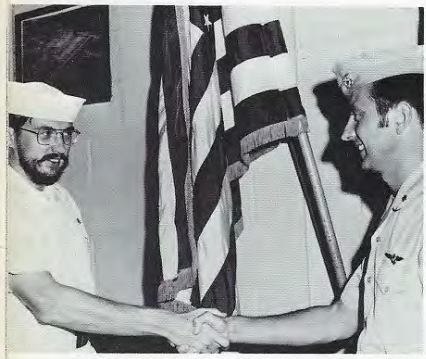

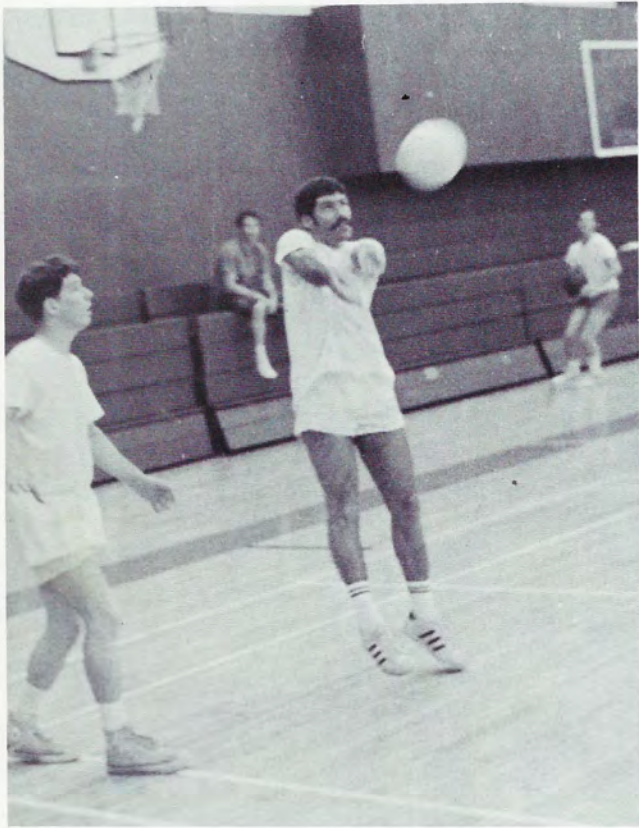

INTRAMURALS



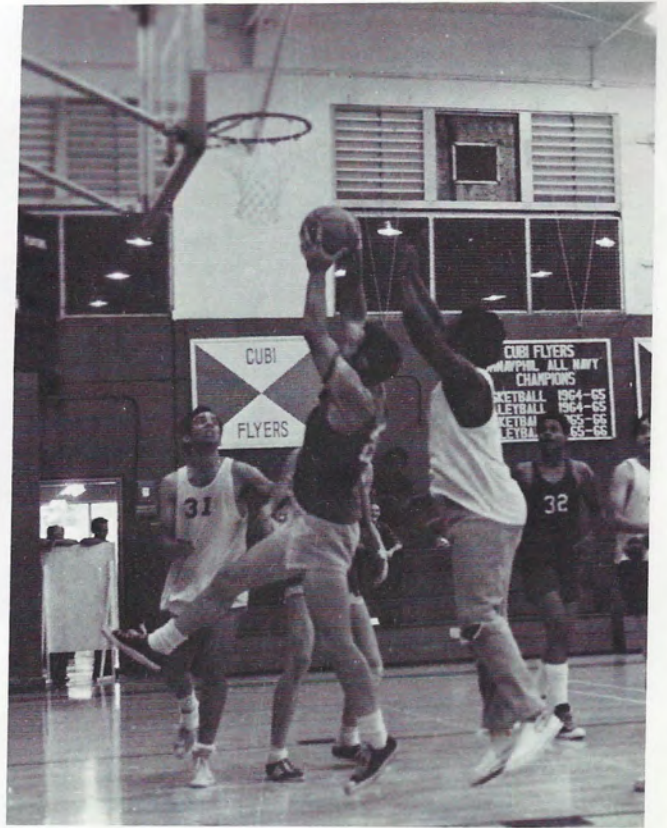

INTRAMURALS

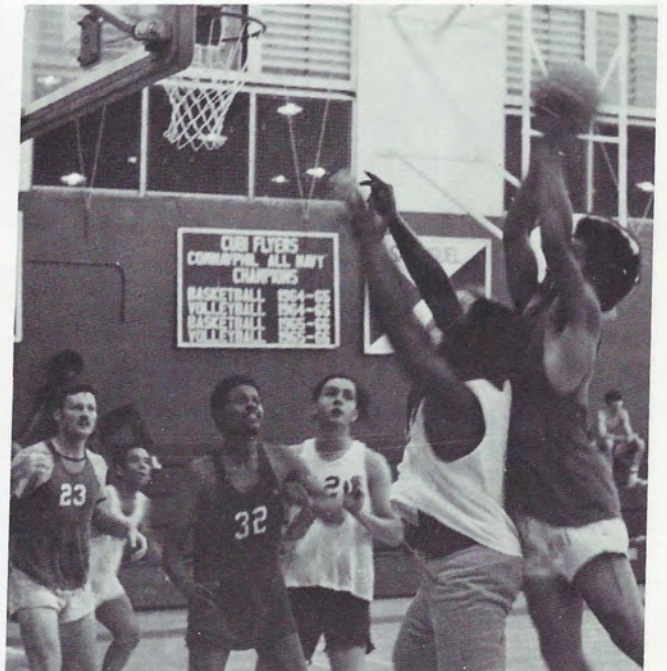



*Another Hard Day
At Work*

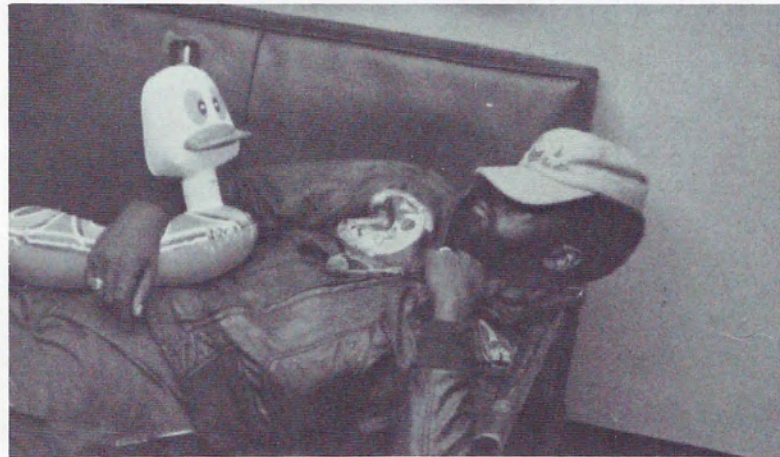
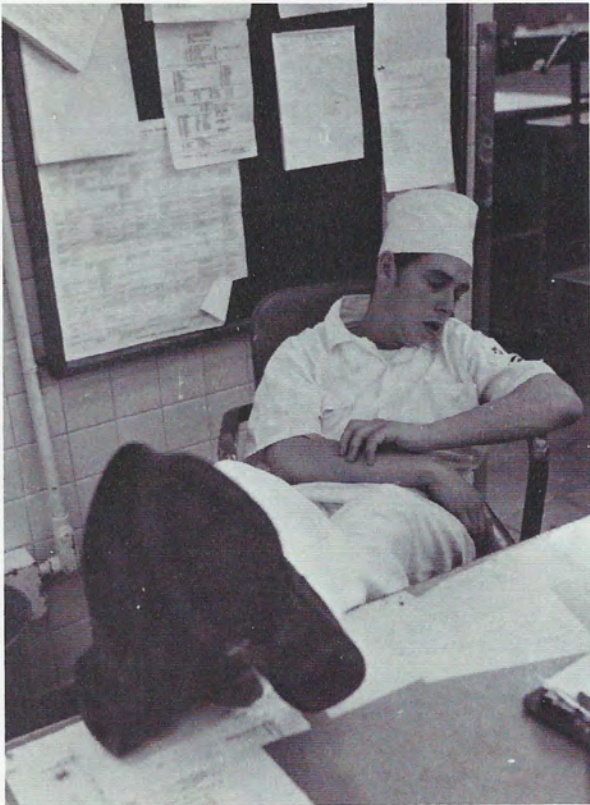

Cool and calm

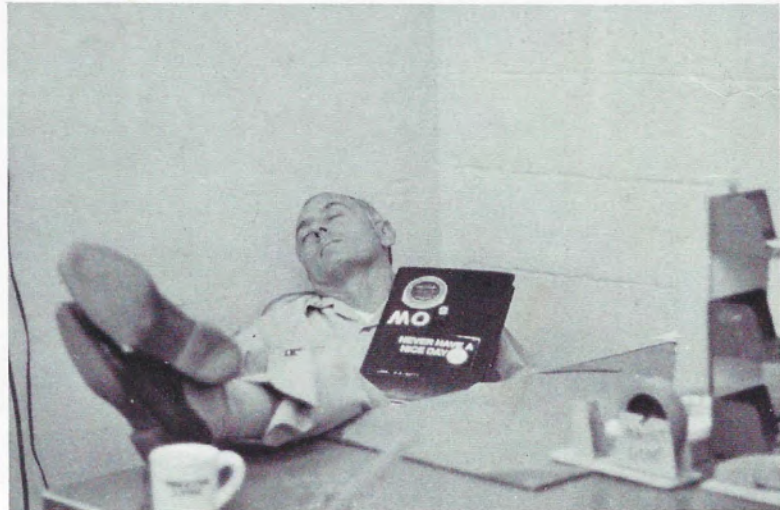

HELP

OUCH!

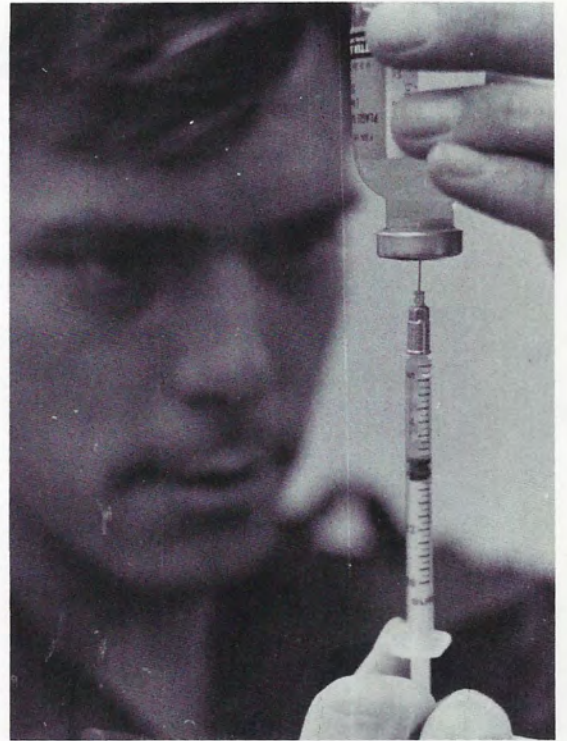
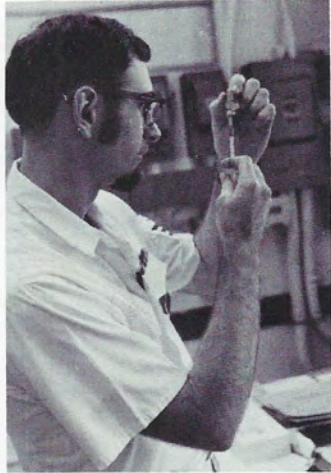
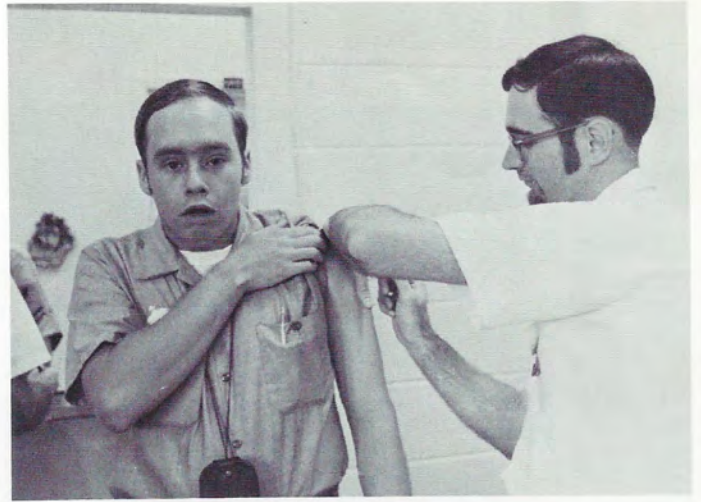

DAY
OF
THE
BIG
PRICK



MOSES THUNDERGUMS MORTIMER
PAT WHIT GEB
SNAKE
SKIPPER "POP" CANNON TREADMOOSE
MIDGET
THIMBLE-BRAINED GHERKIN BEAVER MAGILLA
FOGGY BOBBY GUNRUNNER BULLITT GRAY EAGLE
RAYLA BUCKLES MUNCH
MIGHTY MITE CHIEF FUZZY MDE
PUC COMMANDER CRASH BILLY THE KID
FARLEY SKI
HABU DIRT BAG JR.
GROTY DIEVO J. B.
"L" "J" BUCK SILENT SAM
BILLY BOB SID J.T. IGNATS ALIAS PEANUT-BRAIN GORILLA
ANDY MOOSE KAFLA

I'm not pushing this, but



Eyes wide open

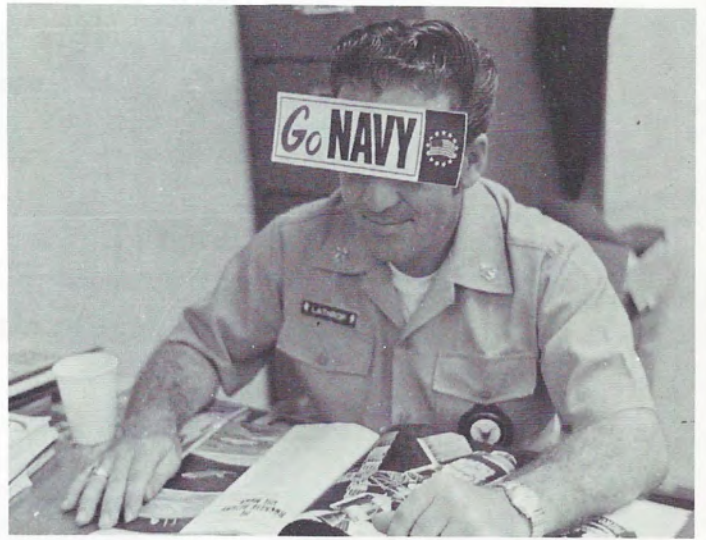

I always wanted to be a pilot

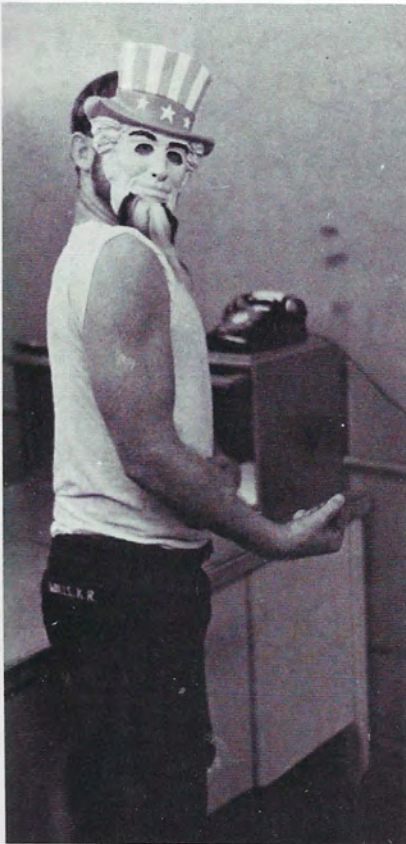

Uncle Sam



It's really fake



Barbequed grasshoppers?

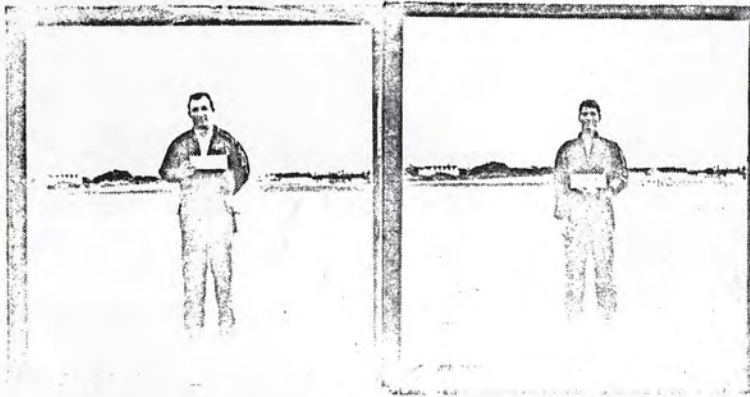

LIKE FATHER

LIKE SON

Robert



The Joys of Flying Jets



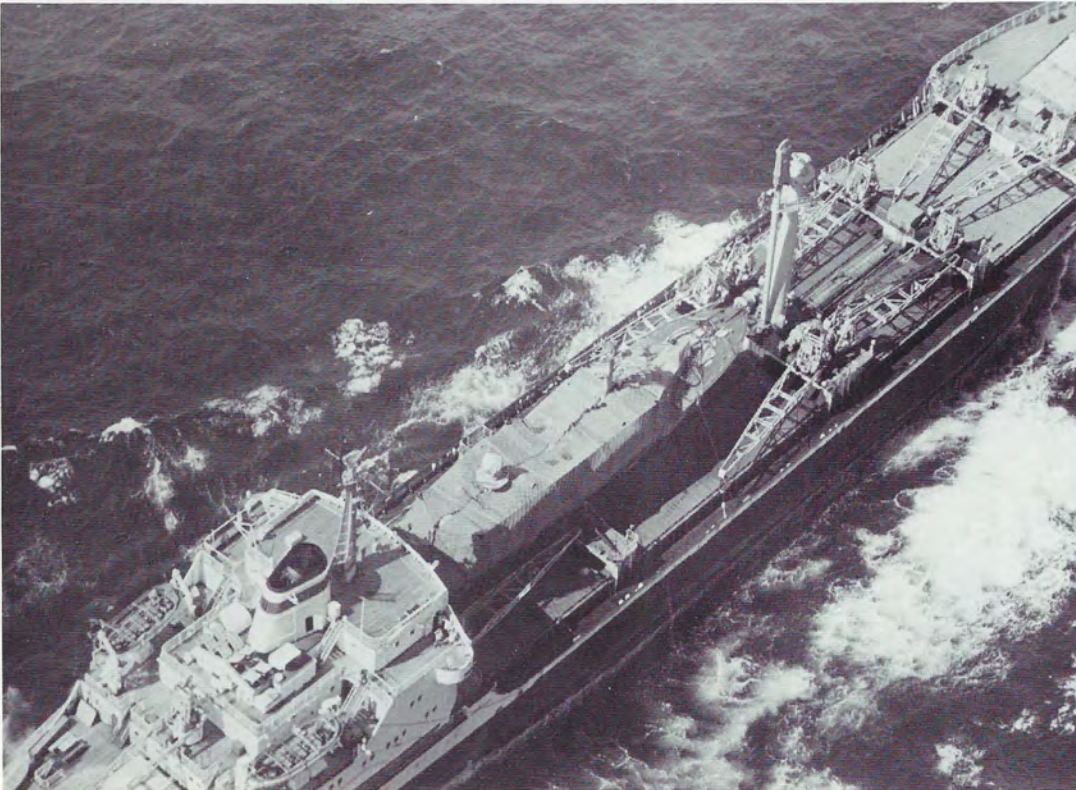
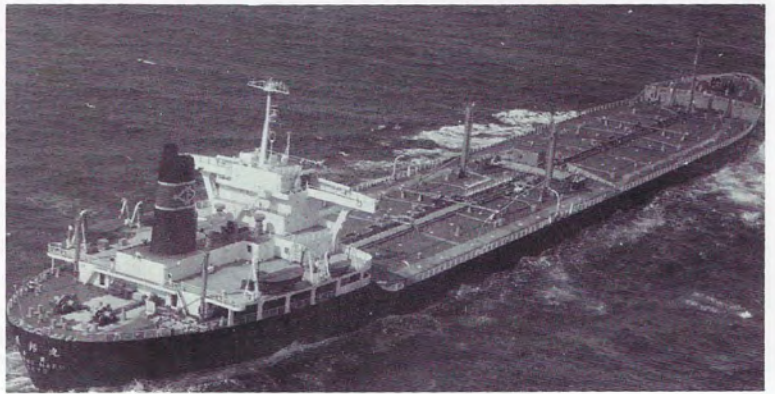
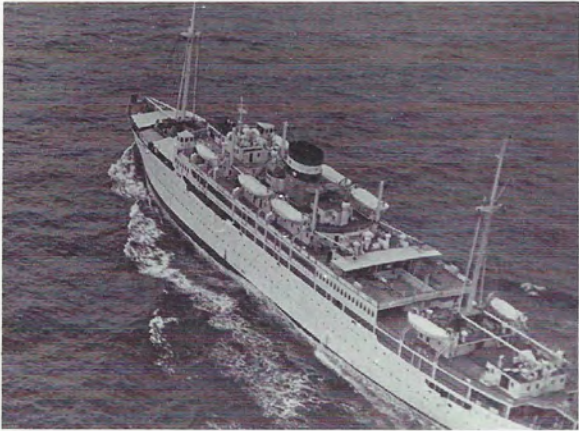

MARK
ON TOP



And I only bought 1877 tickets



The wing and squadron calmly discuss Launching the Ready



Hay skipper



I was supper boy



Lets hear it for couple Number 2

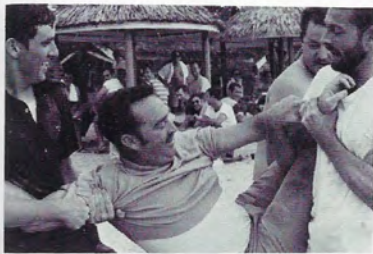

Shower time mister.



I am not hungry



I'd like you to meet my aide, Cdr. Rettig



Do you come here often



Sure Capn, you can get anything with a std. form 44



Fast transportation



Excellent job opportunities

HOME AWAY



Fringe benefits

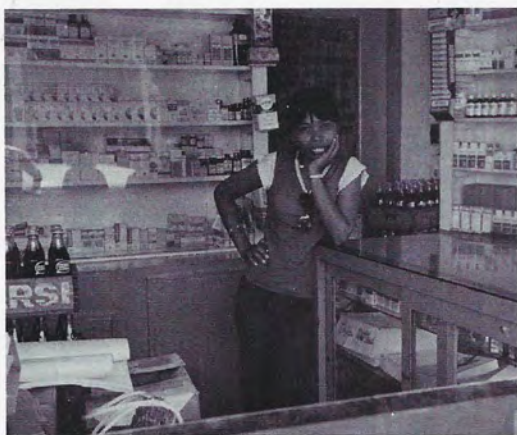

Local stores



Thriving economy

FROM HOME



Modern Housing



Country club



Front view

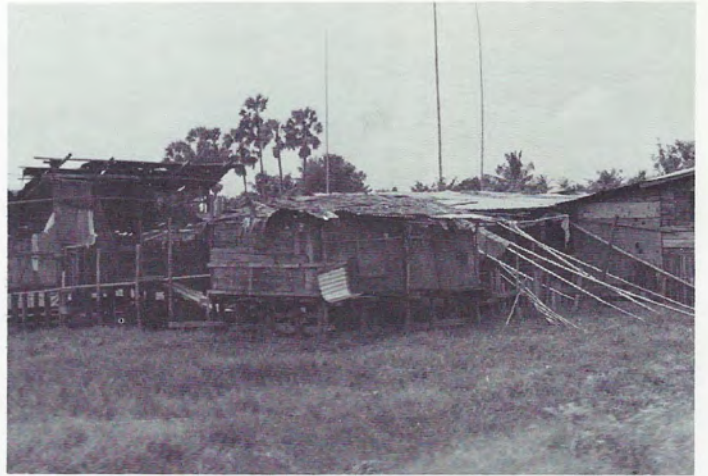

Rear view



Inside



Across the street



Tour guide



Place to be toured



How to get there



If you say so



Those who made muster



3 oz's



Mr. Ed



If I could only read



Preparing for the future



A letter for me?



Little Jack Cornor



Live entertainment



The Dirty OLD Man



Those who missed muster



I hate detachments



This job's a snap



Little Joe



Out with the old - in with the new



Speak no evil



The power of concentration



Now that we have standard uniforms



Friends



Mr. Amerika, the before



How do you spell mother



I found some



Just like home



About those SDO watches

Hard at work



It's not my fault



I get the first piece



Talk to me

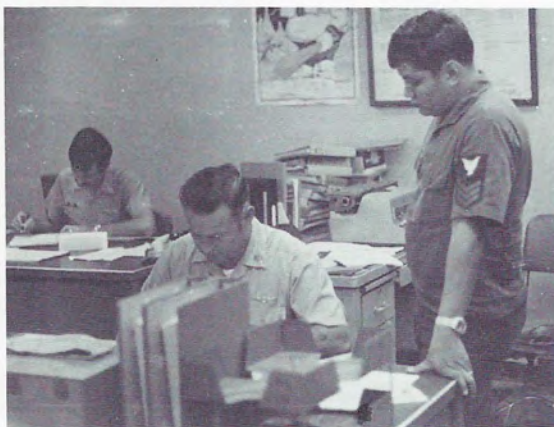

Who me

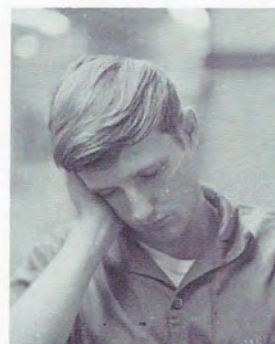

Potential energy

Another sea story

Not again!

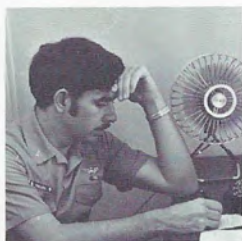

Are you ready



LCDR at work



So you made the list



Man or beast

FOD – where are you?



Paint that



Let the air out and run



It's not this way at the point



Ready alert team



Psss, pass it on



Would you believe a bird strike



Same old jokes



Happiness is!



STAFF

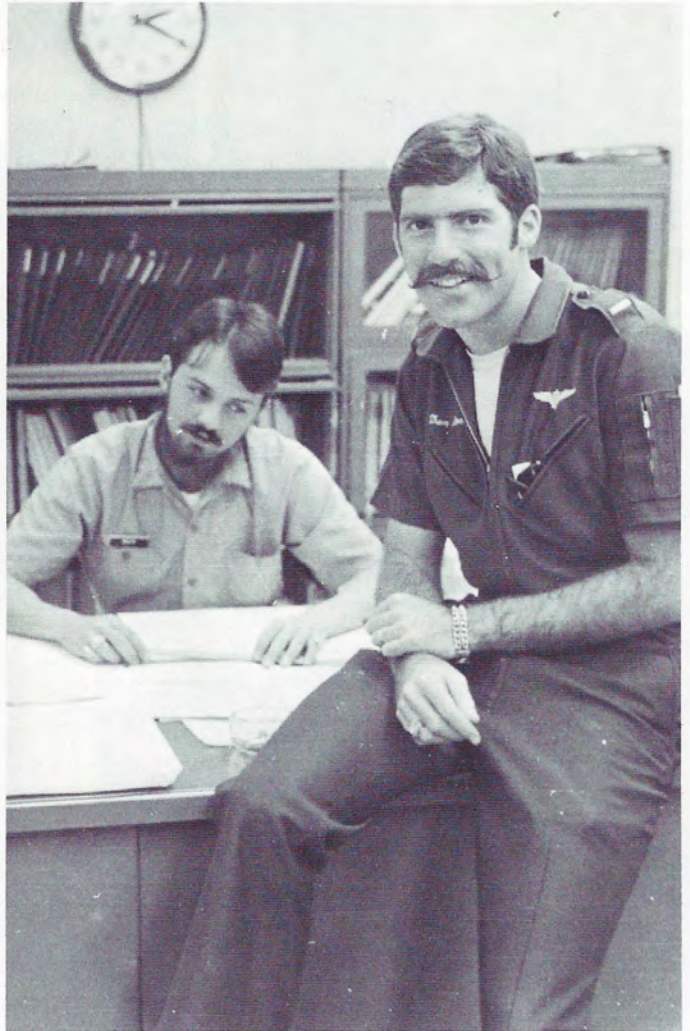
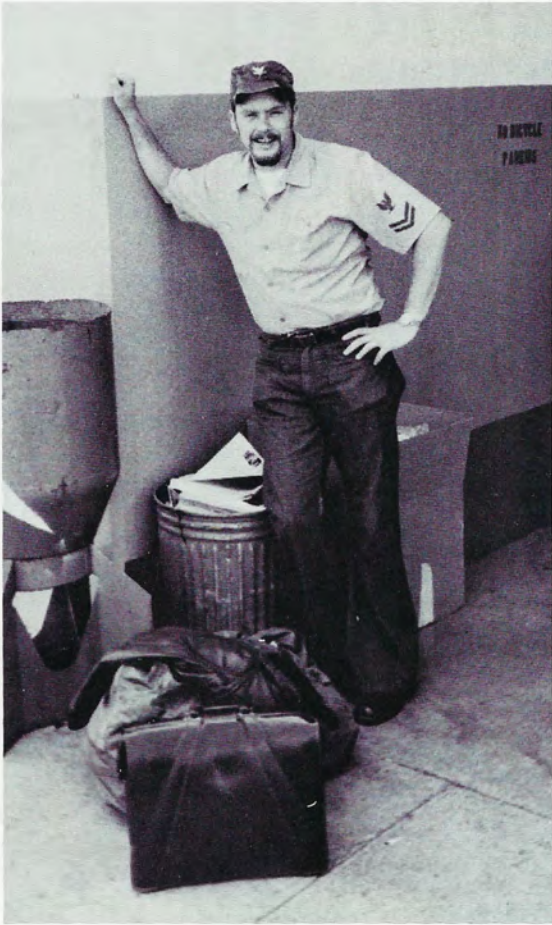

Editors — Steve Wasik & Dan Straus

**Photographers — Doug Siefkin, Dan Straus,
Steve Wasik, & USN**

**Contributors — Too numerous to mention,
but to all who helped:**

THANKS

THE END



On the way



What, I am scheduled for an operational flight already.

OUR ADVANCE PARTY LEAVES
AS VP-22 ARRIVES

THE BEGINNING



Feels so good



A long awaited for moment



O' Daddy



A necessary evil

Back from down under



Getting reacquainted